

HX210S / HX220S

Agriculture Use



Head Office(Sales Office)
11F, GLOBAL R&D CENTER, 477 BUNDANG SUSEO-RO, BUNDANG-GU, SEONGNAM-SI, GYEONGGI-DO, 13553, KOREA

PLEASE CONTACT

Gross Power
148 HP(110 kW) at 2,000rpm

Net Power
145 HP(108 kW) at 2,000rpm

Bucket Capacity
0.52 ~ 1.2m³

Operating Weight
HX210S 20,830 kg / 45,920 lb
HX220S 21,260 kg / 46,870 lb

WHAT'S NEWEST AND BEST

HX210S / HX220S



SUPERIOR PERFORMANCE

- New Variable Power Control
- Hyundai 6BTAA-5.9 (HM5.9)
- Reinforced Bucket and Bucket Linkage
- Powerful and Preciser Swing Control
- Strong and Stable Lower Frame
- Single Layer Cooling System
- Minimization of Shock and Vibration through Cab Mounting System

COMFORTABLE OPERATION

- New Front Side Air-conditioning System
- Smooth Travel Pedal and Foot Rests
- Improved Intelligent Display
- Easy-to-Reach Control Panels
- Wide Cab with Excellent Visibility
- Highly Sensitive Joystick and Easy Entrance
- Wide, Comfortable Operating Space

SERVICEABILITY AND EASY MAINTENANCE

- Easy to Maintain Engine Components
- Centralized Electric Control Box and Easy Change Air Cleaner Assembly
- Side Cover with Left & Right Swing Open Type
- Large tool box for extra storage
- Highly efficient Hydraulic Pump
- Hi-MATE (Remote Management System) Option



SUPERIOR PERFORMANCE

A new chapter in construction equipment has begun.
Making the dream a reality.

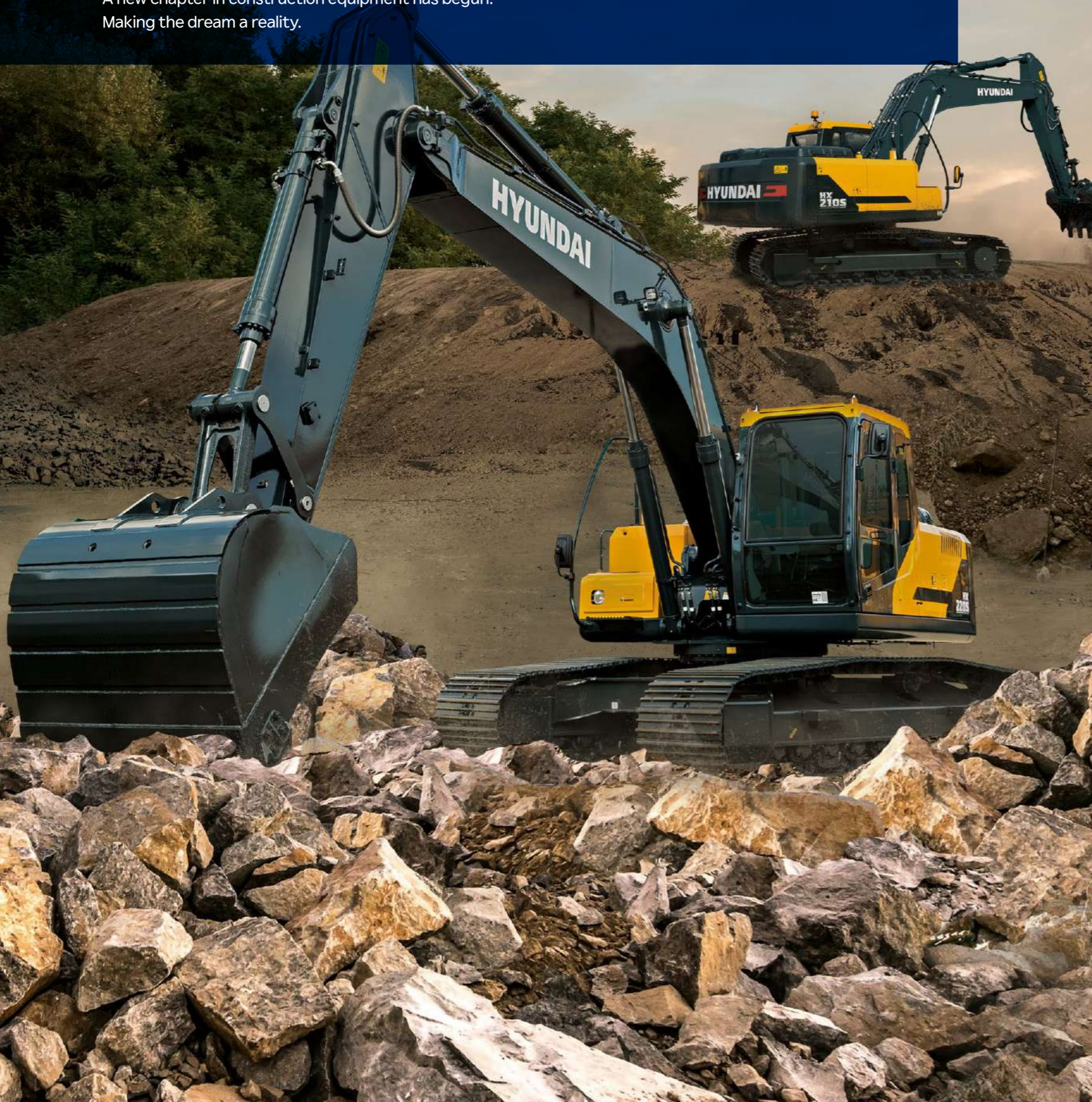

BUILT FOR MAXIMUM POWER, PERFORMANCE, RELIABILITY.

Hyundai 6BTAA-5.9(HM5.9) Engine

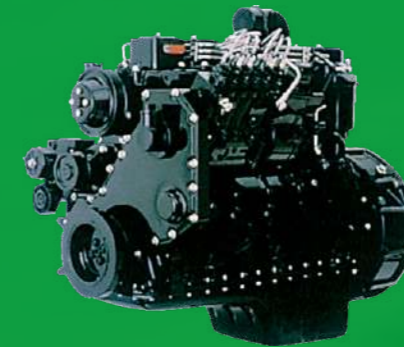

The six cylinders, turbo-charged, 4 cycle, charge air cooled engine is built for power, reliability, economy and low emissions.

Reinforced Bucket and Bucket Linkage



Sealed and adjustable bucket linkage provides less wear of pins and bushes as well as silent operation. The design includes bucket link durability and anti wear characteristics. Additional reinforcement plates on cutting edge section. Reinforced bucket is made with thicker steel and additional lateral plate.

Powerful and Preciser Swing Control



Improved shock absorbing characteristics make stopping a precise and smooth action.

A More Reliable Way To Reach You Dream.

The Hyundai 6BTAA-5.9(HM5.9) engine has been designed with 40% fewer parts than the competition. The weight of the machine is reduced without sacrificing strength. You get a proven power plant that meets ecological concerns, without paying a premium for technology you don't need.

Strong and Stable Lower Frame



Reinforced box-section frame welded, low-stress, high-strength steel. guarantees safety and resistance against external impact when driving on rough ground and working on wet sites through high tensile strength steel panels, with highly durable upper and lower rollers and track guards.

Single Layer Cooling System

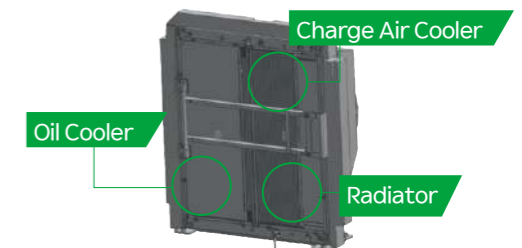

1. Improved cooling performance by changing over to 3 column type structure in a row
2. Easy to clean without disassembling aentire radiator total assembly

Minimization of Shock and Vibration through Cab Mounting System

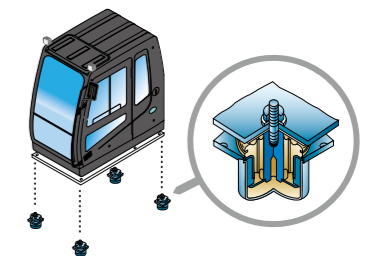

The application of Viscous Mounting to the cab-in support provides the operator with a much improved ride. The operator work efficiency will increase as the shock and noise level in the cabin decreases.



COMFORTABLE OPERATION

Many electronic functions are concentrated in the most convenient spot for operators to improve work efficiency. The highly-advanced infotainment system, a product of HCE's intensive information technology development, enables both productivity and comfort while working! The HX Series is designed with the operator in mind.



OPERATOR'S COMFORT FOREMOST. WIDE CAB EXCEEDS INDUSTRY STANDARDS.

Improved Intelligent Display



Instrument Panel is installed in front of RH console box. It is easy to check all critical systems with easy-to-read indicators.

Smooth Travel Pedal and Foot Rests



Easy-to-Reach Control Panels



Switches and other essential controls are located near the operator. This helps keep operator movement to a minimum, enhancing control with less operator fatigue.

Wide Cab with Excellent Visibility



The cab is roomy and ergonomically designed with low noise level and good visibility. A full view front window and large rear and side windows provide excellent visibility in all directions.

Highly Sensitive Joystick and Easy Entrance



New joystick grips for precise control have been equipped with double switches.
- Left: One touch deceleration
- Right: Horn / Optional

Wide, Comfortable Operating Space



All the controls are designed and positioned according to the latest ergonomic research. Reinforced pillars have also been added for greater cab rigidity.



SERVICEABILITY AND EASY MAINTENANCE

New Cabin for More Comfort.

Low noise, low vibration, and ergonomic design make the cabin space more comfortable and pleasant! With focus on safety and convenience of operators, the HX Series allows rapid and safe equipment inspection anytime and anywhere, providing an optimal environment for operators to work.



HiMATE Option

IT'S CONVENIENT, EASY AND VALUABLE

Hi MATE, Hyundai's newly developed remote management system, utilizes GPS-satellite technology to provide customers with the highest level of service and product support available.

Hi MATE enables users to remotely evaluate machine performance, access diagnostic information, and verify machine locations at the touch of a button.

WHAT IS BENEFITS



Increase Productivity

It helps you operate machines in efficient. You can check the difference between total engine hours and actual working hours. See how productive your machines are and plan any required cost saving solutions. Hi MATE offers working information such as working / idling hours, fuel consumption and rate.



Convenient and Easy Monitoring

There is nothing much to do to monitor your machines. Just log on to the Hi MATE website or mobile application. Hi MATE allows you to watch your machines whenever and wherever you are.



Security

Protect your machines from theft or unauthorized usage with Hi MATE. If the machine moves out of the Geo-fence boundary, you will get alerts

Easy to Maintain Engine Components



The cooling system is provided for optimum operation, guaranteeing longer life for the engine and hydraulic components. Servicing of the engine and hydraulics is considerably simplified due to total accessibility.

Centralized Electric Control Box and Easy Change Air Cleaner Assembly



Electric control box and Air cleaner are centralized in one or the same compartment for easy service.

Side Cover with Left & Right Swing Open Type



Easy access to vital components gives unrestricted view of component allows easy maintenance and repair.

HX210S / HX220S SPECIFICATIONS

| ENGINE | | | |
|----------------------------|--|------------------------------|------------------------------|
| Maker / Model | Hyundai 6BTAA-5.9 (HM5.9) | | |
| Type | Water cooled, 4 cycle Diesel, 6-Cylinders in line, direct injection, Turbocharged, charge air cooled, Low emission | | |
| Rated Flywheel Horse Power | SAE | J1995 (gross) | 148 HP (110 kW) at 2,000 rpm |
| | | J1349 (net) | 145 HP (108 kW) at 2,000 rpm |
| DIN | 6271/1 (gross) | 150 PS (110 kW) at 2,000 rpm | |
| | 6271/1 (net) | 147 PS (108 kW) at 2,000 rpm | |
| Max. Torque | 64 kgf · m (463 lbf · ft) at 1,300 rpm | | |
| Bore X Stroke | 102 X 120 mm (4" X 4.7") | | |
| Piston Displacement | 5,900 cc (360 in ³) | | |
| Batteries | 2 X 12 V X 100 Ah | | |
| Starting Motor | 24 V, 4.5 kW | | |
| Alternator | 24 V, 70 Amp | | |

| HYDRAULIC SYSTEM | |
|---|--|
| MAIN PUMP | |
| Type | Variable displacement tandem-axis piston pumps |
| Max. Flow | 2 X 234 l/min (61.8 USgpm / 51.4 UK gpm) |
| Sub-Pump for Pilot Circuit | Gear pump |
| Cross-sensing and fuel saving pump system | |

| HYDRAULIC MOTORS | |
|------------------|--|
| Travel | Two speed axial pistons motor with brake valve and parking brake |
| Swing | Axial piston motor with automatic brake |

| RELIEF VALVE SETTING | |
|----------------------|-------------------------------------|
| Implement Circuits | 350 kgf/cm ² (4,978 psi) |
| Travel | 350 kgf/cm ² (4,978 psi) |
| Swing Circuit | 265 kgf/cm ² (3,769 psi) |
| Pilot Circuit | 40 kgf/cm ² (568 psi) |
| Service Valve | Installed |

| HYDRAULIC CYLINDERS | |
|---------------------|--|
| No. of Cylinder | Boom: 2-120 X 1,290 mm (4.7" X 50.8") |
| Bore X Stroke | Arm: 1-140 X 1,443 mm (5.5" X 59.4") Bucket: 1-120 X 1,060 mm (4.72" X 41.5") |

| DRIVES & BRAKES | |
|--------------------------------|---|
| Drive Method | Fully hydrostatic type |
| Drive Motor | Axial piston motor, in-shoe design |
| Reduction System | Planetary reduction gear |
| Max. Drawbar Pull | 21,100 kgf (46,500 lbf) |
| Max. Travel Speed (high / low) | 5.7 km/hr (3.54 mph) / 3.5 km/hr (2.17 mph) |
| Gradeability | 35° (70 %) |
| Parking Brake | Multi wet disc |

| CONTROL | |
|---|--|
| Pilot pressure operated joysticks and pedals with detachable lever provide almost effortless and fatigueless operation. | |
| Pilot Control | Two joysticks with one safety lever (LH): Swing and arm, (RH): Boom and bucket (ISO) |
| Traveling and Steering | Two levers with pedals |
| Engine Throttle | Electric, Dial type |
| Lights | One light mounted on the boom and one in the battery box |

| SWING SYSTEM | |
|---------------------------|--|
| Swing Motor | Fixed displacement axial pistons motor |
| Swing Reduction | Planetary gear reduction |
| Swing Bearing lubrication | Grease-bathed |
| Swing Brake | Multi wet disc |
| Swing Speed | 12.2 rpm |

| SERVICE CAPACITIES | | | |
|-----------------------------------|-------|--------|--------|
| | liter | US gal | UK gal |
| Fuel Tank | 340 | 89.8 | 74.8 |
| Engine Coolant | 20 | 5.3 | 4.4 |
| Engine Oil | 20 | 5.3 | 4.4 |
| Swing Device | 6.2 | 1.3 | 1.1 |
| Final Drive (Each) | 4.5 | 1.6 | 1.3 |
| Hydraulic System (Including Tank) | 275 | 72.6 | 60.5 |
| Hydraulic Tank | 160 | 42.3 | 35.2 |

| UNDERCARRIAGE | | |
|--|---------------------|---------------------|
| The X-leg type center frame is integrally welded with reinforced box-section track frames. The undercarriage includes lubricated rollers, idlers, track adjusters with shock absorbing springs and sprockets, and a track chain with double or triple grouser shoes. | | |
| Model | HX210S | HX220S |
| Center Frame | X-leg type | X-leg type |
| Track Frame | Pentagonal box type | Pentagonal box type |
| No. of Shoes on Each Side | 46 EA | 49 EA |
| No. of Carrier Rollers on Each Side | 2 EA | 2 EA |
| No. of Track Rollers on Each Side | 7 EA | 8 EA |
| No. of Rail Guards on Each Side | 1 EA | 2 EA |

| OPERATING WEIGHT (APPROXIMATE) | |
|---|--|
| Operating weight, including 5,700 mm (18' 8") boom, 2,900 mm (9' 6") arm, SAE heaped 0.92m ³ (1.20 yd ³) bucket, lubricant, coolant, full fuel tank, full hydraulic tank, and all standard equipments. | |

| MAJOR COMPONENT WEIGHT | |
|--------------------------|----------------------|
| Upperstructure | 5,600 kg (12,350 lb) |
| Counterweight | 3,600 kg (7,937 lb) |
| Boom (with Arm Cylinder) | 1,950 kg (4,300 lb) |

| OPERATING WEIGHT | | | | |
|------------------|-----------|------------------|-----------------|---------------------------|
| Type | Shoes | Operating Weight | Ground Pressure | |
| | | | kg (lb) | kgf/cm ² (psi) |
| Triple Grouser | 600 (24") | HX210S | 20,830 (45,920) | 0.48 (6.81) |
| | | HX220S | 21,260 (46,870) | 0.45 (6.45) |
| | 700 (28") | HX220S | 21,750 (47,950) | 0.40 (5.66) |
| | | HX210S | 21,380 (47,140) | 0.42 (5.99) |
| 800 (32") | HX220S | 22,040 (48,590) | 0.35 (5.02) | |
| | HX220S LR | 24,390 (53,770) | 0.39 (5.55) | |

HX210S / HX220S BUCKET SELECTION GUIDE & DIGGING FORCE

BUCKETS

All buckets are welded with high-strength steel.

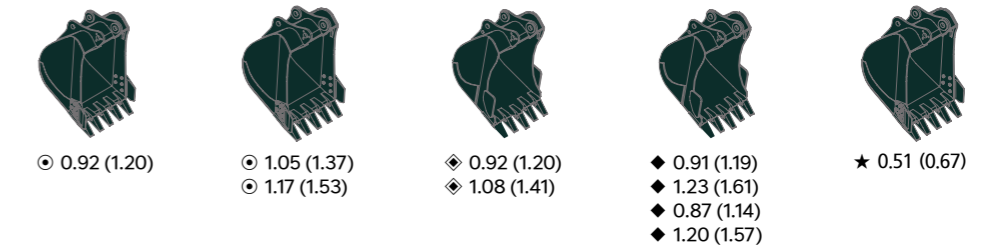

SAE heaped m³ (yd³)

| Type | Capacity m ³ (yd ³) | Width mm (in) | Weight kg (lb) | Tooth EA | Recommendation mm (ft-in) | | | | | | | | |
|---------------|--|---------------|----------------|---------------|---------------------------|--------------------|-------------------|---------------------|---------------------|---------------------|---------------------|---------------------|----------------------|
| | | | | | 3.6 ton CWT | | | | 4.2 ton CWT | | | | 5.3 ton CWT |
| | | | | | 2,000 (6' 7") Arm | 2,400 (7' 10") Arm | 2,900 (9' 6") Arm | 5,700 (18' 8") Boom | 5,700 (18' 8") Boom | 5,680 (18' 8") Boom | 5,680 (18' 8") Boom | 5,680 (18' 8") Boom | 8,500 (27' 11") Boom |
| HX210S | 0.92 (1.20) | 0.81 (1.06) | 1,085 (42.7") | 1,230 (48.4") | 750 (1,650) | 5 | ● | ● | ● | ● | ● | ● | - |
| | 1.05 (1.37) | 0.96 (1.26) | 1,220 (48.0") | 1,370 (53.9") | 790 (1,740) | 5 | ● | ● | ● | ● | ● | ● | - |
| | 1.17 (1.53) | 1.00 (1.31) | 1,340 (52.8") | 1,490 (58.7") | 850 (1,870) | 6 | ● | ● | ● | ● | ● | ● | - |
| | 0.92 (1.20) | 0.83 (1.09) | 1,050 (41.3") | 1,095 (43.1") | 865 (1,910) | 5 | ● | ● | ● | ● | ● | ● | - |
| | 1.08 (1.41) | 0.97 (1.27) | 1,200 (47.2") | 1,245 (49.0") | 935 (2,060) | 5 | ● | ● | ● | ● | ● | ● | - |
| | 0.91 (1.19) | 0.83 (1.09) | 1,050 (41.3") | 1,095 (43.1") | 1,050 (2,310) | 4 | ● | ● | ● | ● | ● | ● | - |
| | 1.23 (1.61) | 1.11 (1.45) | 1,350 (53.1") | 1,395 (54.9") | 1,240 (2,730) | 5 | ● | ● | ● | ● | ● | ● | - |
| HX220S | 0.87 (1.14) | 0.75 (0.98) | 1,150 (45.3") | - | 875 (1,930) | 5 | ● | ● | ● | ● | ● | ● | - |
| | 1.20 (1.57) | 1.00 (1.31) | 1,425 (56.1") | - | 990 (2,180) | 5 | ● | ● | ● | ● | ● | ● | - |
| | 0.92 (1.20) | 0.81 (1.06) | 1,085 (42.7") | 1,230 (48.4") | 750 (1,650) | 5 | ● | ● | ● | ● | ● | ● | - |
| | 1.05 (1.37) | 0.96 (1.26) | 1,220 (48.0") | 1,370 (53.9") | 790 (1,740) | 5 | ● | ● | ● | ● | ● | ● | - |
| | 1.17 (1.53) | 1.00 (1.31) | 1,340 (52.8") | 1,490 (58.7") | 850 (1,870) | 6 | ● | ● | ● | ● | ● | ● | - |
| | 0.92 (1.20) | 0.83 (1.09) | 1,050 (41.3") | 1,095 (43.1") | 865 (1,910) | 5 | ● | ● | ● | ● | ● | ● | - |
| | 1.08 (1.41) | 0.97 (1.27) | 1,200 (47.2") | 1,245 (49.0") | 935 (2,060) | 5 | ● | ● | ● | ● | ● | ● | - |
| 0.91 (1.19) | 0.83 (1.09) | 1,050 (41.3") | 1,095 (43.1") | 1,050 (2,310) | 4 | ● | ● | ● | ● | ● | ● | - | |
| 1.23 (1.61) | 1.11 (1.45) | 1,350 (53.1") | 1,395 (54.9") | 1,240 (2,730) | 5 | ● | ● | ● | ● | ● | ● | - | |
| 0.87 (1.14) | 0.75 (0.98) | 1,150 (45.3") | - | 875 (1,930) | 5 | ● | ● | ● | ● | ● | ● | - | |
| 1.20 (1.57) | 1.00 (1.31) | 1,425 (56.1") | - | 990 (2,180) | 5 | ● | ● | ● | ● | ● | ● | - | |
| ★ 0.51 (0.67) | 0.45 (0.59) | 1,865 (34.1") | 995 (39.2") | 395 (0,870) | 5 | - | - | - | - | - | - | ■ | |

- : General Purpose
- ◆ : Heavy duty bucket
- ◆ : Rock-Heavy duty bucket
- ★ : Long reach bucket
- : Applicable for materials with density of 2,100 kg/m³ (3,500 lb/yd³) or less
- : Applicable for materials with density of 1,800 kg/m³ (3,000 lb/yd³) or less
- : Applicable for materials with density of 1,500 kg/m³ (2,500 lb/yd³) or less
- ▲ : Applicable for materials with density of 1,200 kg/m³ (2,000 lb/yd³) or less
- : Not Recommended

ATTACHMENT

5.70 m (18' 8"), 8.50 m (27' 11") Booms and 2.0 m (6' 7"), 2.4m (7' 10"), 2.9 m (9' 6"), 6.2 m (20' 4") Arms are available.

| Boom | Length | Weight | 5,700 (18' 8") | | | | 8,500 (27' 11") |
|----------------------|--------|--------|-----------------|-----------------|-----------------|-----------------|-----------------|
| | | | kg (lb) | 1,865 (4,110) | | | 2,380 (5,250) |
| Arm | Length | Weight | 2,000 (6' 7") | | | | 2,400 (7' 10") |
| | | | kg (lb) | 820 (1,810) | | | 900 (1,980) |
| Bucket Digging Force | SAE | kN | 130.4 [141.6] | 130.4 [141.6] | 130.4 [141.6] | 130.4 [141.6] | 68.0 [73.7] |
| | | kgf | 13,300 [14,440] | 13,300 [14,440] | 13,300 [14,440] | 13,300 [14,440] | 6,930 [7,520] |
| | | lbf | 29,320 [31,830] | 29,320 [31,830] | 29,320 [31,830] | 29,320 [31,830] | 15,280 [16,580] |
| | ISO | kN | 152.3 [165.3] | 152.3 [165.3] | 152.3 [165.3] | 152.3 [165.3] | 80.3 [87.2] |
| | | kgf | 15,530 [16,860] | 15,530 [16,860] | 15,530 [16,860] | 15,530 [16,860] | 8,190 [8,890] |
| | | lbf | 34,240 [37,170] | 34,240 [37,170] | 34,240 [37,170] | 34,240 [37,170] | 18,060 [19,600] |
| Arm Crowd Force | SAE | kN | 144.3 [156.6] | 119.3 [129.4] | 102.8 [111.6] | 102.8 [111.6] | 49.5 [53.7] |
| | | kgf | 14,710 [15,970] | 12,160 [13,200] | 10,480 [11,380] | 10,480 [11,380] | 5,050 [5,480] |
| | | lbf | 32,430 [35,210] | 26,810 [29,100] | 23,100 [25,090] | 23,100 [25,090] | 11,130 [12,080] |
| | ISO | kN | 152.3 [165.0] | 124.7 [135.4] | 106.9 [116.0] | 106.9 [116.0] | 50.5 [54.8] |
| | | kgf | 15,500 [16,830] | 12,720 [13,810] | 10,900 [11,830] | 10,900 [11,830] | 5,150 [5,590] |
| | | lbf | 34,170 [37,100] | 28,040 [30,450] | 24,030 [26,080] | 24,030 [26,080] | 11,350 [12,320] |

Note: Boom weight includes arm cylinder, piping, and pin
Arm weight includes bucket cylinder, linkage, and pin

DIMENSIONS & WORKING RANGE

HX210S/HX220S DIMENSIONS

5.70 m (18' 8") Boom and 2.0 m (6' 7"), 2.4 m (7' 10"), 2.9 m (9' 6") Arm

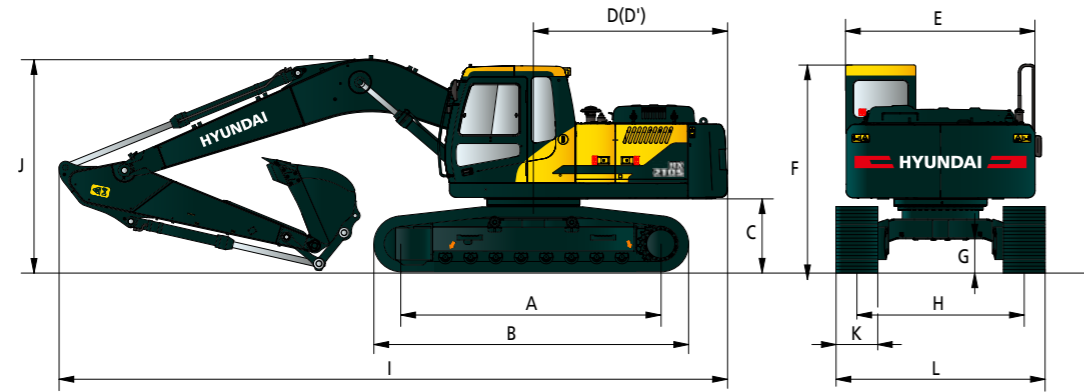

Unit : mm (ft.-in)

| Model | HX210S | HX220S |
|-------------------------------------|----------------|----------------|
| A Tumbler Distance | 3,270 (10' 9") | 3,650 (12' 0") |
| *B Overall Length of Crawler | 4,066 (13' 4") | 4,443 (14' 5") |
| C Ground Clearance of Counterweight | 1,095 (3' 7") | 1,095 (3' 7") |
| D Tail Swing Radius | 2,845 (9' 4") | 2,845 (9' 4") |
| D' Rear-end Length | 2,770 (9' 1") | 2,770 (9' 1") |
| E Overall Width of Upperstructure | 2,700 (8' 10") | 2,700 (8' 10") |
| F Overall Height of Cab | 3,035 (9' 11") | 3,035 (9' 11") |
| G Min. Ground Clearance | 475 (1' 7") | 475 (1' 7") |
| H Track Gauge | 2,200 (7' 3") | 2,390 (7' 10") |

| | | | |
|--------------------------|----------------|----------------|----------------|
| Boom length | 5,700 (18' 8") | | |
| Arm length | 2,000 (6' 7") | 2,400 (7' 10") | 2,900 (9' 6") |
| I Overall Length | 9,620 (31' 7") | 9,575 (31' 5") | 9,550 (31' 4") |
| J Overall Height of Boom | 3,115 (10' 3") | 3,020 (9' 11") | 2,960 (9' 9") |
| HX210S | | | |
| K Track Shoe Width | Type | Triple Grouser | |
| | Width | 600 (24") | 800 (32") |
| L Overall Width | 2,800 (9' 2") | 3,000 (9' 10") | |
| HX220S | | | |
| K Track Shoe Width | Type | Triple Grouser | |
| | Width | 600 (24") | 700 (28") |
| L Overall Width | 2,990 (9' 10") | 3,090 (10' 2") | 3,190 (10' 6") |

HX210S/HX220S WORKING RANGE

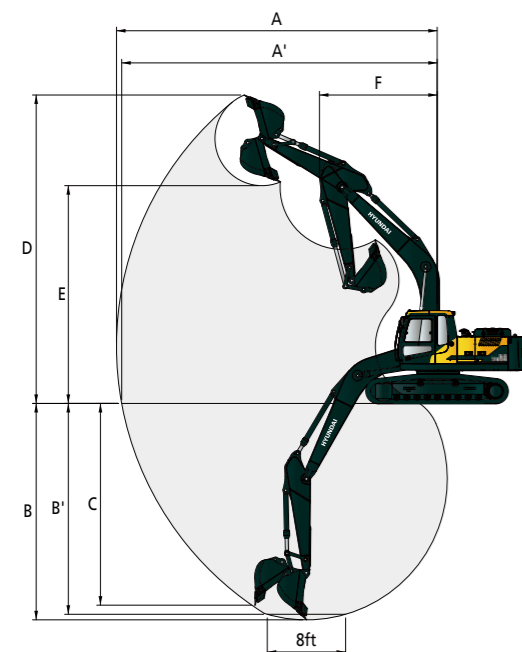

Unit : mm (ft.-in)

| Model | HX210S/220S | | |
|------------------------------------|----------------|-----------------|-----------------|
| Boom Length | 5,700 (18' 8") | | |
| Arm Length | 2,000 (6' 7") | 2,400 (7' 10") | 2,900 (9' 6") |
| A Max. Digging Reach | 9,145 (30' 0") | 9,525 (31' 3") | 9,945 (32' 8") |
| A' Max. Digging Reach on Ground | 8,960 (29' 5") | 9,355 (30' 8") | 9,780 (32' 1") |
| B Max. Digging Depth | 5,585 (18' 4") | 5,990 (19' 8") | 6,500 (21' 4") |
| B' Max. Digging Depth (8' Level) | 5,360 (17' 7") | 5,790 (19' 0") | 6,315 (20' 9") |
| C Max. Vertical Wall Digging Depth | 5,070 (16' 8") | 5,445 (17' 10") | 5,960 (19' 7") |
| D Max. Digging Height | 9,370 (30' 9") | 9,625 (31' 7") | 9,750 (32' 0") |
| E Max. Dumping Height | 6,580 (21' 7") | 6,830 (22' 5") | 6,990 (22' 11") |
| F Min. Swing Radius | 3,715 (12' 2") | 3,400 (11' 2") | 3,425 (11' 3") |

HX220S LONG REACH DIMENSIONS

8.50 m (27' 11") boom, 6.2 m (20' 4") arm

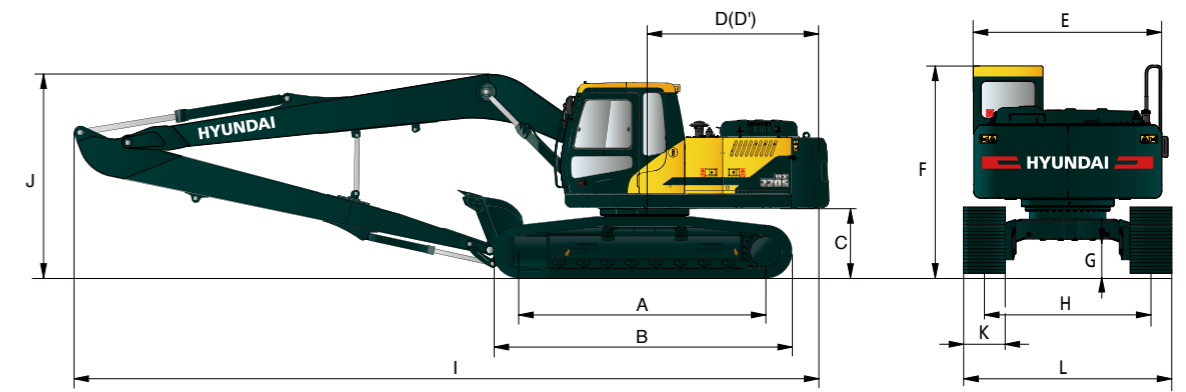

Unit : mm (ft.-in)

| | |
|-------------------------------------|----------------|
| A Tumbler Distance | 3,650 (12' 0") |
| *B Overall Length of Crawler | 4,443 (14' 7") |
| C Ground Clearance of Counterweight | 1,095 (3' 7") |
| D Tail Swing Radius | 2,890 (9' 6") |
| D' Rear-end Length | 2,770 (9' 1") |
| E Overall Width of Upperstructure | 2,740 (9' 0") |
| F Overall Height of Cab | 3,035 (9' 11") |
| G Min. Ground Clearance | 475 (1' 7") |
| H Track Gauge | 2,390 (7' 10") |

| | |
|--------------------------|-----------------|
| Boom Length | 8,500 (27' 11") |
| Arm Length | 6,200 (20' 4") |
| I Overall Length | 12,345 (40' 6") |
| J Overall Height of Boom | 3,365 (11' 0") |
| K Track Shoe Width | 800 (32") |
| L Overall Width | 3,190 (10' 6") |

HX220S LONG REACH WORKING RANGE

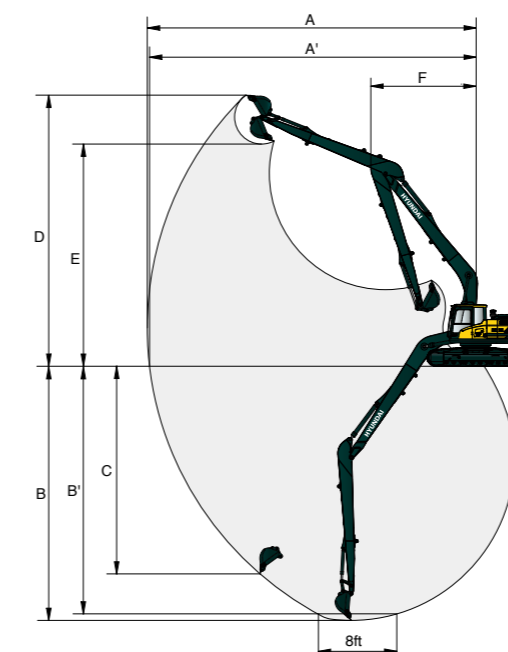

Unit : mm (ft.-in)

| | |
|------------------------------------|-----------------|
| Boom Length | 8,500 (27' 11") |
| Arm Length | 6,200 (20' 4") |
| A Max. Digging Reach | 15,425 (50' 7") |
| A' Max. Digging Reach on Ground | 15,320 (50' 3") |
| B Max. Digging Depth | 11,500 (37' 9") |
| B' Max. Digging Depth (8' Level) | 11,355 (37' 3") |
| C Max. Vertical Wall Digging Depth | 10,265 (33' 8") |
| D Max. Digging Height | 13,445 (44' 1") |
| E Max. Dumping Height | 11,200 (36' 9") |
| F Min. Swing Radius | 4,705 (15' 5") |

HX210S / HX220S

LIFTING CAPACITY

Rating over-front Rating over-side or 360 degree

HX210S MONO BOOM

5.70 m (18' 8") boom, 2.00 m (6' 7") arm equipped with 600 mm (24") triple grouser shoe and 3,600 kg counter weight

| Load Point Height m (ft) | Lift-Point Radius | | | | | | | | At Max. Reach | | |
|-----------------------------|-------------------|-------------------|------------------|------------------|------------------|----------------|----------------|----------------|------------------|-----------------|----------------|
| | 3.0m (9.8ft) | | 4.5m (14.8ft) | | 6.0m (19.7ft) | | 7.5m (24.6ft) | | Capacity | Reach | |
| | | | | | | | | | | | m (ft) |
| 7.5m 24.6ft | kg lb | | | | | | | | *6,130 13,510 | 5,770 12,720 | 5.05 (16.6) |
| 6.0m 19.7ft | kg lb | | *6,180 13,620 | *6,180 13,620 | *5,780 12,740 | 4,360 9,610 | | | *5,810 12,810 | 3,910 8,620 | 6.39 (21.0) |
| 4.5m 14.8ft | kg lb | | *7,370 16,250 | 6,540 14,420 | *6,130 13,510 | 4,240 9,350 | | | 4,890 10,780 | 3,190 7,030 | 7.17 (23.5) |
| 3.0m 9.8ft | kg lb | | | | 6,300 13,890 | 4,030 8,880 | 4,490 9,900 | 2,900 6,390 | 4,410 9,720 | 2,850 6,280 | 7.58 (24.9) |
| 1.5m 4.9ft | kg lb | | | | 6,090 13,430 | 3,840 8,470 | 4,410 9,720 | 2,830 6,240 | 4,260 9,390 | 2,740 6,040 | 7.67 (25.2) |
| 0.0m 0.0ft | kg lb | | 9,270 20,440 | 5,530 12,190 | 5,970 13,160 | 3,730 8,220 | | | 4,400 9,700 | 2,810 6,190 | 7.46 (24.5) |
| -1.5m -4.9ft | kg lb | | 9,290 20,480 | 5,550 12,240 | 5,960 13,140 | 3,720 8,200 | | | 4,900 10,800 | 3,110 6,860 | 6.92 (22.7) |
| -3.0m -9.8ft | kg lb | *11,600 25,570 | 10,880 23,990 | *8,810 19,420 | 5,680 12,520 | | | | 6,180 13,620 | 3,900 8,600 | 5.95 (19.5) |

5.70 m (18' 8") boom, 2.40 m (7' 10") arm equipped with 600 mm (24") triple grouser shoe and 3,600 kg counter weight

| Load Point Height m (ft) | Lift-Point Radius | | | | | | | | At Max. Reach | | |
|-----------------------------|-------------------|-------------------|------------------|------------------|------------------|-----------------|-----------------|----------------|------------------|-----------------|----------------|
| | 3.0m (9.8ft) | | 4.5m (14.8ft) | | 6.0m (19.7ft) | | 7.5m (24.6ft) | | Capacity | Reach | |
| | | | | | | | | | | | m (ft) |
| 7.5m 24.6ft | kg lb | | | | | | | | *5,580 12,300 | 4,880 10,760 | 5.62 (18.4) |
| 6.0m 19.7ft | kg lb | | | *5,340 11,770 | 4,410 9,720 | | | | 5,360 11,820 | 3,510 7,740 | 6.85 (22.5) |
| 4.5m 14.8ft | kg lb | | *6,830 15,060 | 6,630 14,620 | *5,770 12,720 | 4,260 9,390 | 4,570 10,080 | 2,970 6,550 | 4,480 9,880 | 2,910 6,420 | 7.58 (24.9) |
| 3.0m 9.8ft | kg lb | | *8,560 18,870 | 6,090 13,430 | 6,320 13,930 | 4,040 8,910 | 4,480 9,880 | 2,890 6,370 | 4,070 8,970 | 2,620 5,780 | 7.97 (26.1) |
| 1.5m 4.9ft | kg lb | | 9,440 20,810 | 5,660 12,480 | 6,080 13,400 | 3,830 8,440 | 4,380 9,660 | 2,800 6,170 | 3,940 8,690 | 2,520 5,560 | 8.06 (26.4) |
| 0.0m 0.0ft | kg lb | | 9,220 20,330 | 5,480 12,080 | 5,930 13,070 | 3,690 8,140 | 4,310 9,500 | 2,730 6,020 | 4,040 8,910 | 2,570 5,670 | 7.85 (25.8) |
| -1.5m -4.9ft | kg lb | *9,280 20,460 | *9,280 20,460 | 9,200 20,280 | 5,460 12,040 | 5,890 12,990 | 3,660 8,070 | | 4,450 9,810 | 2,820 6,220 | 7.34 (24.1) |
| -3.0m -9.8ft | kg lb | *12,580 27,730 | 10,660 23,500 | *9,230 20,350 | 5,560 12,260 | 5,970 13,160 | 3,730 8,220 | | 5,430 11,970 | 3,420 7,540 | 6.44 (21.1) |
| -4.5m -14.8ft | kg lb | | *6,610 14,570 | 5,840 12,870 | | | | | | | |

5.70 m (18' 8") boom, 2.90 m (9' 6") arm equipped with 600 mm (24") triple grouser shoe and 3,600 kg counter weight

| Load Point Height m (ft) | Lift-Point Radius | | | | | | | | At Max. Reach | | | | |
|-----------------------------|-------------------|------------------|------------------|-------------------|-------------------|------------------|-----------------|-----------------|----------------|-----------------|------------------|----------------|----------------|
| | 1.5m (4.9ft) | | 3.0m (9.8ft) | | 4.5m (14.8ft) | | 6.0m (19.7ft) | | 7.5m (24.6ft) | | Capacity | Reach | |
| | | | | | | | | | | | | | m (ft) |
| 7.5m 24.6ft | kg lb | | | | | | | | | | *4,330 9,550 | 4,200 9,260 | 6.21 (20.4) |
| 6.0m 19.7ft | kg lb | | | | | *4,830 10,650 | 4,470 9,850 | | | | *4,030 8,880 | 3,150 6,940 | 7.34 (24.1) |
| 4.5m 14.8ft | kg lb | | | *6,130 13,510 | *6,130 13,510 | *5,330 11,750 | 4,310 9,500 | 4,600 10,140 | 3,000 6,610 | *3,960 8,730 | 2,650 5,840 | 8.03 (26.3) | |
| 3.0m 9.8ft | kg lb | | | *7,880 17,370 | 6,210 13,690 | *6,120 13,490 | 4,070 8,970 | 4,490 9,900 | 2,890 6,370 | 3,750 8,270 | 2,400 5,290 | 8.39 (27.5) | |
| 1.5m 4.9ft | kg lb | | | *9,500 20,940 | 5,710 12,590 | 6,090 13,430 | 3,830 8,440 | 4,360 9,610 | 2,780 6,130 | 3,630 8,000 | 2,310 5,090 | 8.48 (27.8) | |
| 0.0m 0.0ft | kg lb | | *4,930 10,870 | *4,930 10,870 | 9,190 20,260 | 5,440 11,990 | 5,900 13,010 | 3,660 8,070 | 4,270 9,410 | 2,690 5,930 | 3,700 8,160 | 2,340 5,160 | 8.28 (27.2) |
| -1.5m -4.9ft | kg lb | *5,620 12,390 | *5,620 12,390 | *9,410 20,750 | *9,410 20,750 | 9,110 20,080 | 5,370 11,840 | 5,820 12,830 | 3,590 7,910 | 4,240 9,350 | 2,660 5,860 | 7.80 (25.6) | |
| -3.0m -9.8ft | kg lb | | | *13,620 30,030 | 10,420 22,970 | 9,180 20,240 | 5,430 11,970 | 5,860 12,920 | 3,620 7,980 | | 4,770 10,520 | 3,000 6,610 | 6.96 (22.8) |
| -4.5m -14.8ft | kg lb | | | *10,720 23,630 | *10,720 23,630 | *7,730 17,040 | 5,640 12,430 | | | | *5,820 12,830 | 4,180 9,220 | 5.60 (18.4) |

1 | Lifting capacity are based on ISO 10567.

2 | Lifting capacity of HX Series does not exceed 75% of tipping load with the machine on firm, level ground or 87% of full hydraulic capacity.

3 | The Lift-point is bucket pivot mounting pin on the arm (without bucket mass).

4 | (*) indicates load limited by hydraulic capacity.

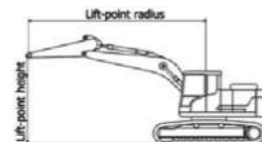

Rating over-front Rating over-side or 360 degree

HX220S MONO BOOM

5.70 m (18' 8") boom, 2.00 m (6' 7") arm equipped with 600 mm (24") triple grouser shoe and 3,600 kg counter weight

| Load Point Height m (ft) | Lift-Point Radius | | | | | | | | At Max. Reach | | |
|-----------------------------|-------------------|-------------------|-------------------|------------------|------------------|------------------|-----------------|----------------|------------------|------------------|----------------|
| | 3.0m (9.8ft) | | 4.5m (14.8ft) | | 6.0m (19.7ft) | | 7.5m (24.6ft) | | Capacity | Reach | |
| | | | | | | | | | | | m (ft) |
| 7.5m 24.6ft | kg lb | | | | | | | | *6,130 13,510 | *6,130 13,510 | 5.05 (16.6) |
| 6.0m 19.7ft | kg lb | | | *6,170 13,600 | *6,170 13,600 | *5,780 12,740 | 4,850 10,690 | | *5,810 12,810 | 4,360 9,610 | 6.39 (21.0) |
| 4.5m 14.8ft | kg lb | | | *7,370 16,250 | 7,320 16,140 | *6,130 13,510 | 4,720 10,410 | | 5,510 12,150 | 3,560 7,850 | 7.17 (23.5) |
| 3.0m 9.8ft | kg lb | | | | | 6,300 13,890 | 4,030 8,880 | 4,490 9,900 | 4,410 9,720 | 2,850 6,280 | 7.58 (24.9) |
| 1.5m 4.9ft | kg lb | | | | | 6,090 13,430 | 3,840 8,470 | 4,410 9,720 | 4,260 9,390 | 2,740 6,040 | 7.67 (25.2) |
| 0.0m 0.0ft | kg lb | | | 9,270 20,440 | 5,530 12,190 | 5,970 13,160 | 3,730 8,220 | | 4,400 9,700 | 2,810 6,190 | 7.46 (24.5) |
| -1.5m -4.9ft | kg lb | | | 9,290 20,480 | 5,550 12,240 | 5,960 13,140 | 3,720 8,200 | | 4,900 10,800 | 3,110 6,860 | 6.92 (22.7) |
| -3.0m -9.8ft | kg lb | *11,600 25,570 | *11,600 25,570 | *8,810 19,420 | 5,680 12,520 | | | | 6,180 13,620 | 3,900 8,600 | 5.95 (19.5) |

5.70 m (18' 8") boom, 2.40 m (7' 10") arm equipped with 600 mm (24") triple grouser shoe and 3,600 kg counter weight

| Load Point Height m (ft) | Lift-Point Radius | | | | | | | | At Max. Reach | | | |
|-----------------------------|-------------------|-------------------|------------------|------------------|------------------|------------------|----------------|-----------------|------------------|-----------------|----------------|----------------|
| | 3.0m (9.8ft) | | 4.5m (14.8ft) | | 6.0m (19.7ft) | | 7.5m (24.6ft) | | Capacity | Reach | | |
| | | | | | | | | | | | m (ft) | |
| 7.5m 24.6ft | kg lb | | | | | | | | *5,580 12,300 | 5,430 11,970 | 5.62 (18.4) | |
| 6.0m 19.7ft | kg lb | | | | | *5,340 11,770 | 4,410 9,720 | | 5,360 11,820 | 3,910 8,620 | 6.85 (22.5) | |
| 4.5m 14.8ft | kg lb | | | *6,820 15,040 | *6,820 15,040 | *5,770 12,720 | 4,260 9,390 | 4,570 10,080 | 2,970 6,550 | 3,250 7,170 | 7.58 (24.9) | |
| 3.0m 9.8ft | kg lb | | | *8,560 18,870 | 6,090 13,430 | 6,320 13,930 | 4,040 8,910 | 4,480 9,880 | 2,890 6,370 | 4,590 10,120 | 2,940 6,480 | 7.97 (26.1) |
| 1.5m 4.9ft | kg lb | | | 9,440 20,810 | 5,660 12,480 | 6,080 13,400 | 3,830 8,440 | 4,380 9,660 | 2,800 6,170 | 3,140 6,920 | 2,830 6,240 | 8.06 (26.4) |
| 0.0m 0.0ft | kg lb | | | 9,220 20,330 | 5,480 12,080 | 5,930 13,070 | 3,690 8,140 | 4,310 9,500 | 2,730 6,020 | 4,170 9,190 | 2,890 6,370 | 7.85 (25.8) |
| -1.5m -4.9ft | kg lb | *9,270 20,440 | *9,270 20,440 | 9,200 20,280 | 5,460 12,040 | 5,890 12,990 | 3,660 8,070 | | 4,450 9,810 | 2,820 6,220 | 7.34 (24.1) | |
| -3.0m -9.8ft | kg lb | *12,590 27,760 | 12,350 27,230 | *9,230 20,350 | 5,560 12,260 | 5,970 13,160 | 3,730 8,220 | | 5,430 11,970 | 3,420 7,540 | 6.44 (21.1) | |
| -4.5m -14.8ft | kg lb | | | *6,620 14,590 | 5,840 12,870 | | | | | | | |

5.70 m (18' 8") boom, 2.90 m (9' 6") arm equipped with 600 mm (24") triple grouser shoe and 3,600 kg counter weight

| Load Point Height m (ft) | Lift-Point Radius | | | | | | | | At Max. Reach | | | | |
|-----------------------------|-------------------|------------------|--------------|------------------|------------------|------------------|-----------------|-----------------|----------------|-----------------|-----------------|----------------|----------------|
| | 1.5m (4.9ft) | | 3.0m (9.8ft) | | 4.5m (14.8ft) | | 6.0m (19.7ft) | | 7.5m (24.6ft) | | Capacity | Reach | |
| | | | | | | | | | | | | | m (ft) |
| 7.5m 24.6ft | kg lb | | | | | | | | | | *4,330 9,550 | 4,330 9,550 | 6.21 (20.4) |
| 6.0m 19.7ft | kg lb | | | | | *4,830 10,650 | 4,470 9,850 | | | | *4,030 8,880 | 3,510 7,740 | 7.34 (24.1) |
| 4.5m 14.8ft | kg lb | | | *6,130 13,510 | *6,130 13,510 | *5,330 11,750 | 4,310 9,500 | 4,600 10,140 | 3,000 6,610 | *3,960 8,730 | 2,650 5,840 | 8.03 (26.3) | |
| 3.0m 9.8ft | kg lb | | | *7,880 17,370 | 6,210 13,690 | *6,120 13,490 | 4,070 8,970 | 4,490 9,900 | 2,890 6,370 | 3,750 8,270 | 2,400 5,290 | 8.39 (27.5) | |
| 1.5m 4.9ft | kg lb | | | *9,500 20,940 | 5,710 12,590 | 6,090 13,430 | 3,830 8,440 | 4,360 9,610 | 2,780 6,130 | 3,630 8,000 | 2,310 5,090 | 8.48 (27.8) | |
| 0.0m 0.0ft | kg lb | | | *4,930 10,870 | *4,930 10,870 | 9,190 20,260 | 5,440 11,990 | 5,900 13,010 | 3,660 8,070 | 4,270 9,410 | 2,690 5,930 | 3,700 8,160 | 8.28 (27.2) |
| -1.5m -4.9ft | kg lb | *5,620 12,390 | | | | | | | | | | | |

HX210S / HX220S LIFTING CAPACITY

Rating over-front Rating over-side or 360 degree

HX220S LONG REACH BOOM

8.5 m (27' 11") boom, 6.2 m (20' 4") arm equipped with 800 mm (32") triple grouser shoe, and 5,300 kg (11,690 lb) counterweight.

| Load Point Height m (ft) | Lift-Point Radius | | | | | | | | | | | | | | | | At Max. Reach | | | | | | | |
|-----------------------------|-------------------|---------|--------------|---------|---------------|---------|---------------|---------|---------------|---------|---------------|--------|----------------|--------|----------------|--------|----------------|--------|----------|--------|--------|--------|--------|--------|
| | 1.5m (4.9ft) | | 3.0m (9.8ft) | | 4.5m (14.8ft) | | 6.0m (19.7ft) | | 7.5m (24.6ft) | | 9.0m (29.5ft) | | 10.5m (34.4ft) | | 12.0m (39.4ft) | | 13.5m (44.3ft) | | Capacity | Reach | | | | |
| | | | | | | | | | | | | | | | | | | | m (ft) | m (ft) | | | | |
| 12.0m 39.4ft | kg | | | | | | | | | | | | | | | | | | *970 | *970 | 9.79 | | | |
| | lb | | | | | | | | | | | | | | | | | | *2,140 | *2,140 | (32.1) | | | |
| 10.5m 34.4ft | kg | | | | | | | | | | | | | *1,530 | *1,530 | | | | *880 | *880 | 11.17 | | | |
| | lb | | | | | | | | | | | | | *3,370 | *3,370 | | | | *1,940 | *1,940 | (36.6) | | | |
| 9.0m 29.5ft | kg | | | | | | | | | | | | | *2,000 | *2,000 | *1,090 | *1,090 | | *830 | *830 | 12.21 | | | |
| | lb | | | | | | | | | | | | | *4,410 | *4,410 | *2,400 | *2,400 | | *1,830 | *1,830 | (40.0) | | | |
| 7.5m 24.6ft | kg | | | | | | | | | | | | | *2,050 | *2,050 | *1,800 | *1,800 | | *810 | *810 | 12.99 | | | |
| | lb | | | | | | | | | | | | | *4,520 | *4,520 | *3,970 | *3,970 | | *1,790 | *1,790 | (42.6) | | | |
| 6.0m 19.7ft | kg | | | | | | | | | | | | | *2,170 | *2,170 | *2,110 | 1,940 | *880 | *880 | *800 | *800 | 13.55 | | |
| | lb | | | | | | | | | | | | | *4,780 | *4,780 | *4,650 | 4,280 | *1,940 | *1,940 | *1,760 | *1,760 | (44.5) | | |
| 4.5m 14.8ft | kg | | | | | | | | | | | | | *2,530 | *2,530 | *2,350 | *2,350 | *2,220 | 1,860 | *1,430 | *1,430 | *810 | *810 | 13.94 |
| | lb | | | | | | | | | | | | | *5,580 | *5,580 | *5,180 | *5,180 | *4,890 | 4,100 | *3,150 | *3,150 | *1,790 | *1,790 | (45.7) |
| 3.0m 9.8ft | kg | | | | | *5,420 | *5,420 | *4,030 | *4,030 | *3,300 | *3,300 | *2,850 | *2,850 | *2,560 | 2,260 | *2,360 | 1,770 | *1,770 | 1,400 | *840 | *840 | 14.15 | | |
| | lb | | | | | *11,950 | *11,950 | *8,880 | *8,880 | *7,280 | *7,280 | *6,280 | *6,280 | *5,640 | 4,980 | *5,200 | 3,900 | *3,900 | 3,090 | *1,850 | *1,850 | (46.4) | | |
| 1.5m 4.9ft | kg | | | | | *6,960 | *6,960 | *4,860 | 4,840 | *3,810 | 3,550 | *3,180 | 2,710 | *2,780 | 2,120 | *2,510 | 1,680 | *1,960 | 1,340 | *880 | *880 | 14.20 | | |
| | lb | | | | | *15,340 | *15,340 | *10,710 | 10,670 | *8,400 | 7,830 | *7,010 | 5,970 | *6,130 | 4,670 | *5,530 | 3,700 | *4,320 | 2,950 | *1,940 | *1,940 | (46.6) | | |
| 0.0m 0.0ft | kg | | | | | *2,670 | *2,670 | *6,320 | *6,320 | *5,550 | 4,370 | *4,260 | 3,250 | *3,490 | 2,510 | *2,990 | 1,990 | *2,650 | 1,590 | *1,970 | 1,290 | *940 | *940 | 14.08 |
| | lb | | | | | *5,890 | *5,890 | *13,930 | *13,930 | *12,240 | 9,630 | *9,390 | 7,170 | *7,690 | 5,530 | *6,590 | 4,390 | *5,840 | 3,510 | *4,340 | 2,840 | *2,070 | *2,070 | (46.2) |
| -1.5m -4.9ft | kg | *2,530 | *2,530 | *3,460 | *3,460 | *6,060 | 6,020 | *6,000 | 4,070 | *4,600 | 3,030 | *3,740 | 2,360 | 3,150 | 1,880 | 2,590 | 1,520 | *1,670 | 1,250 | *1,040 | *1,040 | 13.81 | | |
| | lb | *5,580 | *5,580 | *7,630 | *7,630 | *13,360 | 13,270 | *13,230 | 8,970 | *10,140 | 6,680 | *8,250 | 5,200 | 6,940 | 4,140 | 5,710 | 3,350 | *3,680 | 2,760 | *2,290 | *2,290 | (45.3) | | |
| -3.0m -9.8ft | kg | *3,520 | *3,520 | *4,440 | *4,440 | *6,700 | 5,910 | *6,220 | 3,920 | *4,810 | 2,900 | 3,820 | 2,250 | 3,080 | 1,810 | 2,550 | 1,480 | | | *1,170 | *1,170 | 13.36 | | |
| | lb | *7,760 | *7,760 | *9,790 | *9,790 | *14,770 | 13,030 | *13,710 | 8,640 | *10,600 | 6,390 | 8,420 | 4,960 | 6,790 | 3,990 | 5,620 | 3,260 | | | *2,580 | *2,580 | (43.8) | | |
| -4.5m -14.8ft | kg | *4,540 | *4,540 | *5,560 | *5,560 | *7,810 | 5,920 | *6,230 | 3,880 | *4,860 | 2,840 | 3,770 | 2,210 | 3,040 | 1,780 | 2,540 | 1,470 | | | *1,360 | *1,360 | 12.71 | | |
| | lb | *10,010 | *10,010 | *12,260 | *12,260 | *17,220 | 13,050 | *13,730 | 8,550 | *10,710 | 6,260 | 8,310 | 4,870 | 6,700 | 3,920 | 5,600 | 3,240 | | | *3,000 | *3,000 | (41.7) | | |
| -6.0m -19.7ft | kg | *5,640 | *5,640 | *6,840 | *6,840 | *8,000 | 6,040 | *6,020 | 3,920 | *4,750 | 2,850 | 3,780 | 2,210 | 3,060 | 1,790 | | | | | *1,650 | 1,540 | 11.84 | | |
| | lb | *12,430 | *12,430 | *15,080 | *15,080 | *17,640 | 13,320 | *13,270 | 8,640 | *10,470 | 6,280 | 8,330 | 4,870 | 6,750 | 3,950 | | | | | *3,640 | 3,400 | (38.8) | | |
| -7.5m -24.6ft | kg | *6,860 | *6,860 | *8,360 | *8,360 | *7,280 | 6,240 | *5,570 | 4,040 | *4,430 | 2,930 | *3,580 | 2,280 | *2,850 | 1,880 | | | | | *2,170 | 1,840 | 10.68 | | |
| | lb | *15,120 | *15,120 | *18,430 | *18,430 | *16,050 | 13,760 | *12,280 | 8,910 | *9,770 | 6,460 | *7,890 | 5,030 | *6,280 | 4,140 | | | | | *4,780 | 4,060 | (35.0) | | |
| -9.0m -29.5ft | kg | | | *8,410 | *8,410 | *6,130 | *6,130 | *4,760 | 4,240 | *3,760 | 3,100 | *2,880 | 2,450 | | | | | | | *2,800 | 2,410 | 9.13 | | |
| | lb | | | *18,540 | *18,540 | *13,510 | *13,510 | *10,490 | 9,350 | *8,290 | 6,830 | *6,350 | 5,400 | | | | | | | *6,170 | 5,310 | (30.0) | | |

- Lifting capacity are based on ISO 10567.
- Lifting capacity of the HX A Series does not exceed 75% of tipping load with the machine on firm, level ground or 87% of full hydraulic capacity.
- The Lift-point is bucket pivot mounting pin on the arm (without bucket mass).
- (*) indicates load limited by hydraulic capacity.

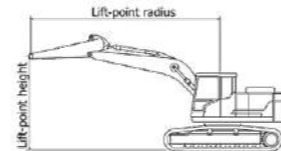

HX210S / HX220S STANDARD / OPTION

| ENGINE | STD | OPT |
|--|--------------------|-----|
| Hyundai 6BTAA-5.9 (HM5.9) | ● | |
| HYDRAULIC SYSTEM | | |
| 3-power mode, 2-work mode, user mode | ● | |
| Variable power control | ● | |
| Engine auto idle | ● | |
| CAB & INTERIOR | | |
| ISO STANDARD CABIN | | |
| Rise-up type windshield wiper | ● | |
| Radio / USB player | | ● |
| 12 volt power outlet (24V DC to 12V DC converter) | ● | |
| Electric horn | ● | |
| All-weather steel cab with 360° visibility | ● | |
| Sliding fold-in front window | ● | |
| Sliding side window(LH) | ● | |
| Lockable door | ● | |
| Storage compartment | ● | |
| Sun visor | ● | |
| Door and cab locks, one key | ● | |
| Mechanical suspension seat | ● | |
| Pilot-operated slidable joystick | ● | |
| Cabin lights | | ● |
| Cabin roof-steel cover | ● | |
| AUTOMATIC CLIMATE CONTROL | | |
| Air conditioner & heater | ● | |
| Defroster | ● | |
| Starting aid (air grid heater) for cold weather | ● | |
| CENTRALIZED MONITORING | | |
| Engine speed or trip meter / Accel. | ● | |
| Engine coolant temperature gauge | ● | |
| Max power | ● | |
| Low speed / High speed | ● | |
| Auto idle | ● | |
| Air cleaner clogging | ● | |
| Indicators | ● | |
| Fuel level gauge | ● | |
| Hyd. oil temperature gauge | ● | |
| Fuel warmer | | ● |
| Warnings | ● | |
| Communication error | ● | |
| Low battery | ● | |
| Clock | ● | |
| CABIN FOPS (ISO 10262) LEVEL 2 | | |
| FOPS (Falling Object Protective Structure)-ISO 10262 Level 2 | Front & Tops guard | ● |

| SAFETY | STD | OPT |
|--|-----|-----|
| Battery master switch | ● | |
| Two front working lights (1 boom mounted, 1 front frame mounted) | ● | |
| Travel alarm | | ● |
| Beacon lamp | | ● |
| Automatic swing brake | ● | |
| Boom holding system | ● | |
| Arm holding system | ● | |
| Two outside rearview mirror | ● | |
| Wire net guard | | ● |
| ATTACHMENT | | |
| BOOMS | | |
| 5.70m, 18' 8" Mono | | ● |
| 5.70m, 18' 8" Heavy Duty | | ● |
| 8.50m, 27' 11" Long Reach | | ● |
| ARMS | | |
| 2.00m, 6' 7" | | ● |
| 2.40m, 7' 10" | | ● |
| 2.90m, 9' 6" | ● | |
| 2.90m, 9' 6" Heavy Duty | | ● |
| 6.20m, 20' 4" | | ● |
| OTHERS | | |
| Pre-Cleaner | | ● |
| Removable clean-out dust net for cooler | ● | |
| Removable reservoir tank | ● | |
| Fuel pre-filter | ● | |
| Fuel warmer | | ● |
| Self-diagnostics system | ● | |
| Hi MATE (Remote Management System) | | ● |
| Batteries (2 x 12V x 100 AH) | ● | |
| Fuel filler pump (35 L/min) | | ● |
| Single-acting piping kit (breaker, etc.) | | ● |
| Accumulator for lowering work equipment | ● | |
| Tool kit | | ● |
| COUNTERWEIGHT | | |
| 3.6 ton CWT | | ● |
| 4.2 ton CWT | | ● |
| 5.3 ton CWT | | ● |
| UNDERCARRIAGE | | |
| Lower frame under cover (additional) | | ● |
| Lower frame under cover (normal) | ● | |
| TRACK SHOES | | |
| Triple grousers shoes (600mm, 24") | ● | |
| Triple grousers shoe (700mm, 28") | | ● |
| Triple grousers shoe (800mm, 32") | | ● |
| Track rail guard | ● | |

* Standard and optional equipment may vary. Contact your Hyundai dealer for more information.
 The machine may vary according to International standards.
 * The photos may include attachments and optional equipment that are not available in your area.
 * Materials and specifications are subject to change without advance notice.
 * All imperial measurements rounded off to the nearest pound or inch.

