

# STANDARD/OPTION

DESCRIPTION	HDT90	HDT105
BATTERY-165A	○	○
HEATER-ENGINE BLOCK	○	○
OIL-COLD OIL KIT	○	○
RETARDER-HYDRAULIC	○	○
WATER SPRAY-BRAKE DEVICE	○	○
HEATER-BODY-CARGO BODY	○	○
CHAIN-IRON-TAIL GATE	○	○
CAMERA-AAVM	○	○
LAMP-DRIVING-HALOGEN	●	●
LAMP-DRIVING-LED	○	○
PROTECTOR-FUEL TANK-GRID	○	○
SEAT-2"4P BELT	○	○
FUEL TANK-500L	●	●
FUEL TANK-700L-DUAL CHAMBER	x	x
TIRE-STD 14.00-25	●	x
TIRE-STD 16.00-25	x	●
TIRE-14.00R25 KUNLUN	○	x
TIRE-16.00R25 E-3 AEOLUS	x	○
TIRE-14.00R25 QIANJIN	○	x
TIRE-16.00R25 E-3 QIANJIN	x	○
TIRE-16.00R25 E-3 SAILUN	x	○
EXTENSION-BODY SIDE (30 CBM) WITH REAR DOOR	●	x
EXTENSION-BODY SIDE (33 CBM) WITH REAR DOOR	○	x
EXTENSION-BODY SIDE (33 CBM) WITHOUT REAR DOOR	○(ONLY FOR IDN)	x
EXTENSION-BODY SIDE (36 CBM) WITH REAR DOOR	x	●
EXTENSION-BODY SIDE (40 CBM) WITH REAR DOOR	x	○
EXTENSION-BODY SIDE (40 CBM) WITHOUT REAR DOOR	x	○(ONLY FOR IDN)
CABIN POSITION (LEFT HAND SIDE)	●	●
CABIN POSITION (RIGHT HAND SIDE)	○	○
EMERGENCY STEERING	○	○
WHEELCHOCK	○	○
REAR VIEW CAMERA	○	○
BUMPER TAIL	○	○
BACKBUZZER	○	○
ALARM-CARGO LIFTING	○	○
REMOVER- STONE	○	○
AUTOGREASE	○	○
LOCK SPARE TIRE	○	○

\* ●:STD, ○:OPTION, x: N/A



# HDT90/HDT105

Wide-body Dump Truck

TIER3



**Net Weight**

HDT90 30,000 kg  
HDT105 35,000 kg

**Rated Power**

395 kW (300 HP) at 2,100 rpm

**Body Volume**

HDT90 30 m<sup>3</sup>  
HDT105 36 m<sup>3</sup>

**Rated Payload**

HDT90 60,000 kg  
HDT105 70,000 kg

PLEASE CONTACT



# PRODUCTIVITY & EFFICIENCY THE ULTIMATED DUMP TRUCK

HDT90/HDT105

With new upgraded system, the truck has great load capacity and high comprehensive transportation benefits.

The core patented technology of HDT90/HDT105 is of a flexible structure frame, which has strong absorption and attenuation shock ability, thereby significantly reducing the failure rate of truck chassis.

Full hydraulic steering and emergency steering system can be more light, reliable and safe.



## Powerful and cost effective



- New performance-optimized engine, high efficient and fuel-saving.
- 13L large displacement, strong power and wide power range.

## Intelligent design for improved economy

### Automatic transmission

- High reliability and torque transmission capability.
- The integrated hydraulic retarder provides excellent auxiliary braking capability for heavy duty trucks and improves operation safety.

### Main frame

- Flexible bolt and rivet connection frame type with high torsional bearing efficiency and long service life.

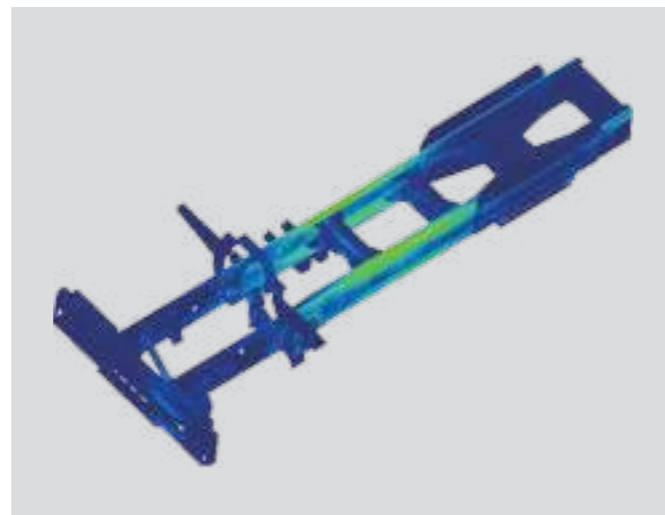

### Lifting Device

- Specialized mine version lifting system with reliable and greater thrust.
- Optimization design of connecting bracket to strengthen support and improve lift safety.



# SUPERIOR RELIABILITY AND DURABILITY

HDT90/HDT105

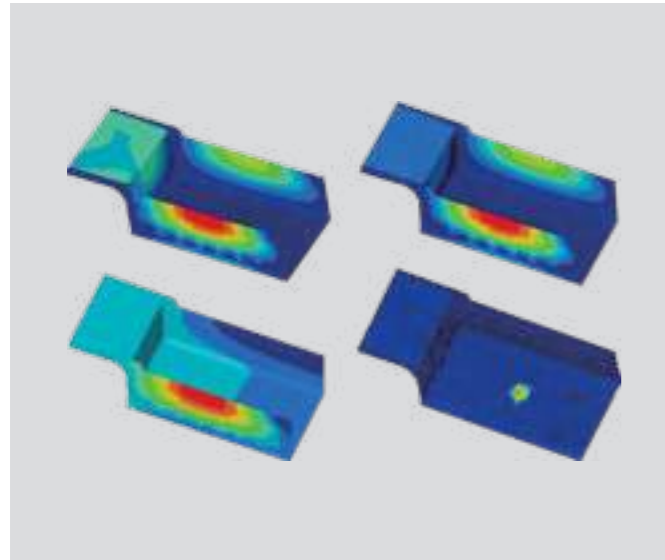

## Cargo body

Reinforced structure with strong impact resistance.

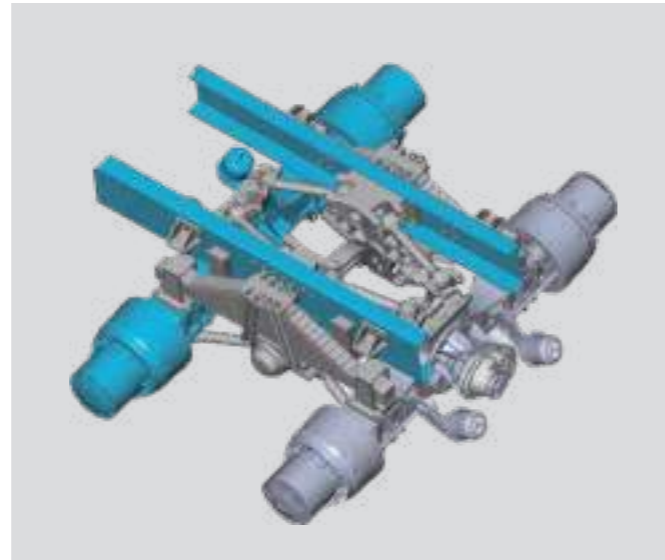

## Suspension system

- The front suspension multi-level shock absorption element to improve driving comfort.
- The rear leaf spring clamping mechanism is reliable and practical.



## Steering system

Reduce the steering oil temperature, steering operation is lighter, greatly improve the life cycle of the system components, and ensure the truck safety.



## Hydraulic retarder

Transmission combined with hydraulic retarder can reduce the speed of the truck when going down a long slope, works long time and high power, reduce the wear out of braking components and extend the tire life time, ensure the operation safety.



## Tire

Special mining tire for mine only with longitudinal and transverse groove design, which provide excellent grip performance, comfort of operation, strong carrying capacity and long service life.



## Intake system

Three stage combined air filter can improve the efficiency of air filtering, and improve the air cleanliness.



## Axle Assembly

- The special axle for mine transportation. Strengthened single casting axle housing, double reduction.
- Big torque, high transmission efficiency and high reliability.



## Special cab for mining truck

- The new generation cap with large space, wide visible range and comfortable manipulation.
- Compression molding interior with lower noise and good quality.

## SPECIFICATIONS

Engine	HDT90	HDT105
Engine Model	Weichai 530 horse power	
Rated Power	530HP at 2,100rpm	
No. of Cylinders	6	
Max. Torque	234.5 kgf·m	
Displacement	13L	13L
Bore Diameter×Stroke	127 X 165	127×165
Air Filter	Third level desert filtration	
Emissions	Non road Stage 3	

Hydraulic system	HDT90	HDT105
Type	single-cylinder front lift	
Maximum Pump Output	22MPa	
Filtration	High pressure filter	
Main Safety valve Pressure Tipping	22MPa	
Main Safety valve Pressure Steering circuit	16MPa	
Tilt Cylinders	FC191	
Tipping Time Raise	25	27
Tipping Time Lower	25	27
Main Pumps Rated Flow	250 l /min	
Implement Circuit	230 kgf/cm <sup>2</sup>	

BODY	HDT90	HDT105
Body Volume (Without Tailgate)	30m <sup>3</sup>	36m <sup>3</sup>
Material	High strength wear-resistant plate	
Body Tipping Angle	50°	
Level Capacity	30m <sup>3</sup>	36m <sup>3</sup>
Heaped capacity	37m <sup>3</sup>	43m <sup>3</sup>

Axle	HDT90	HDT105
Load/T	20+35+35	25+40+40

Tires	HDT90	HDT105
Standard	14.00-25	16.00-25

CONTAINER	HDT90	HDT105
Base plate material/ thickness (mm)	NM400/16	
Rear plate material/ thickness (mm)	NM400/12	
Front plate material/ thickness (mm)	T700/10	
Side plate material/ thickness (mm)	T700/10	
Container volume (m <sup>3</sup> )	30	36

Weight distribution	HDT90	HDT105	
Empty load	Front axle (kg)	10000	15000
	Rear axle (kg)	20000	
	Total weight (50% fuel) (kg)	30000	35000
Loaded	Front axle (kg)	20000	25000
	Rear axle (kg)	70000	80000
	Total weight (kg)	90000	105000

STEERING SYSTEM	HDT90	HDT105
Steering device	Fully hydraulic steering	
Cylinder	HLG1606	
Max. Steering Angle	37°	

Tank Capacity	HDT90	HDT105
Heaped Capacity	500L	600L
Engine Oil	27L	
Hydraulic Tank	200L	

Performance	HDT90	HDT105
Travel Speed (forward, Max.)	40km/h	
Travel Speed (Reverse, Max.)	7km/h	

## DIMENSIONS

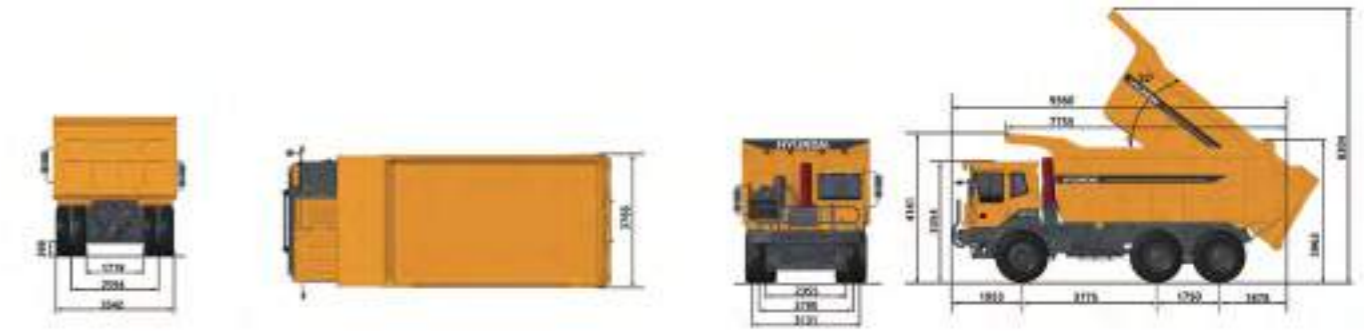

Dimensions	HDT90	HDT105
Transport position/ cab height	3258	3354
Over outside front tire	14.00-25	16.00-25
Over outside rear tire	14.00-25	16.00-25
Between inner tires	2680/2500	2838/2626
Ground clearance front axle	305	400
Ground clearance rear axle	305	400
Ground clearance body fully tipped	600	800
Front axle centre to machine front	1953	
Front axle centre to art hinge	6160	6419
Art hinge to rear axle centre	534	595
Rear axle centre to body tip	3106	3426
Front axle centre to rear axle centre	4075	
Wheelbase rear axle	1550	1750
Approach angle front	27°	28°
Max. body tip angle	50°	
Max. steering angle	37°	
Load height (SAE 2:1)	4373	4638
Inner turning radius	8.4M	
Outer turning radius	11m	
Corridor width	Single lane>6m, Two-lane>11m	