

HYUNDAI

MATERIAL HANDLING

CLASS III

- Pallet Truck
- Electric Stacker
- Tow Tractor
- Low-level Order Picker





A SOLUTION FOR MAXIMIZING THE VERSATILITY OF THE WAREHOUSE

Efficient horizontal movement is a crucial factor in warehouse management.

The Hyundai class III electric pallet series facilitates logistics movement more easily and quickly through efficient horizontal movement.

Based on powerful and excellent AC motors and Curtis controller, this series offers various models and options suitable for almost all horizontal handling situations, from short shuttles to long distances.

Contents	Pallet Truck	04
	Electric Stacker	30
	Tow Tractor	50
	Low-level Order Picker	54

Pallet Trucks Family

12EP-XB
 • 1.2T Capacity **Li-ion**

- Perfect for light-duty applications
- Compact & skeleton design
- Fast-charging Li-ion batteries
- Ideal for occasional operations
- Easy-battery replacement
- High maneuverability

DC 24V



15EP-XB
 • 1.5T Capacity **Li-ion**

- Perfect for light-duty applications
- Compact & skeleton design
- Light service weight
- Fast-charging Li-ion batteries
- Ideal for use on retail stores, lorries
- Easy-battery replacement

DC 24V



20EP-XB
 • 2.0T Capacity **Li-ion**

- Ultimate solution for heavy loads move
- Compact & robust design
- Fast-charging Li-ion batteries
- Easy-battery replacement
- Great grade-ability performance
- Powerful drive & pump system

BLDC 48V



Smart and Ergonomic Tillers

The Edge series trucks are configured with control tillers adopted to meet with application needs based on trucks designated performance.



RFID card access is standard for 20EP-XB optional for all other models

RFID card provides faster access to equipment and ideal for applications when one truck needs to be used by different operators.



The tiller bar is supported by the air spring which helps to return the tiller to its vertical position without strike in the end point.

For increase of operation comfort and safety the trucks are equipped with speed reduction function in turns. (Optional for 12EP-XB and 15EP-XB, standard for other trucks)

The value of speed reduction is adjustable according to customers' preferences.

Smart & Replaceable Batteries for Pallet Trucks

The ***xxEP-XB trucks** are equipped with maintenance-free Li-ion batteries, optional capacities for various applications are available, with its fast charging and opportunity charging features (charge whenever you want and as long as time allows) the operation time can be extended significantly.

All pallet trucks batteries are located in battery compartments securely, any possibility of movement is excluded, therefore the reliability of power supply is ensured.

*: xx=Capacity

Light weight of the battery(max. 8kg) and the easiest way of fast battery replacement allows even a female operator to double the working time within seconds. The light weight of the batteries can be achieved through use of Li-ion battery type with high ratio of energy density to its self-weight.



All Li-ion batteries are equipped with on-board Battery Management System (BMS), which provides mandatory control of all important parameters of the battery during charging and operation. With this control, the safety of Li-ion battery during the whole life-cycle is guaranteed. The Li-ion batteries are certified according to international safety transportation (by sea and by air) and operation standards. The BMS communicates with control system of the truck via CAN, the support of the CAN protocols allows to monitor the condition of the battery and make its diagnosis with help of special software which is available for our partners.



Optional different battery capacities from 20Ah to 36Ah for various applications

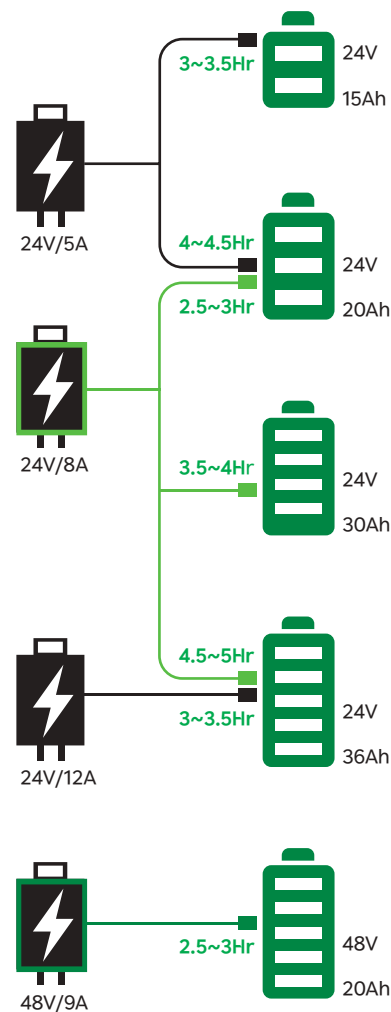

Manage your working time with selection of batteries and chargers



Socket on battery case for easy battery charging without necessity to take the battery out.



The positioning of the battery inside the battery compartment is fast and easy thanks to specially designed battery guiding system.



Battery cases for pallet trucks are made out of ABS PC material with 15% of glass fiber.

The ***xxEP-XB trucks** remains unpowered while charger is connected with the battery charging socket even if the charger is disconnected from the power outlet, therefore, the safety is ensured and the possibility to damage the charger is excluded.

*: xx=Capacity

100% min. **2.5** hours charge | Excellent working time



Gradeability Performance & Robustness

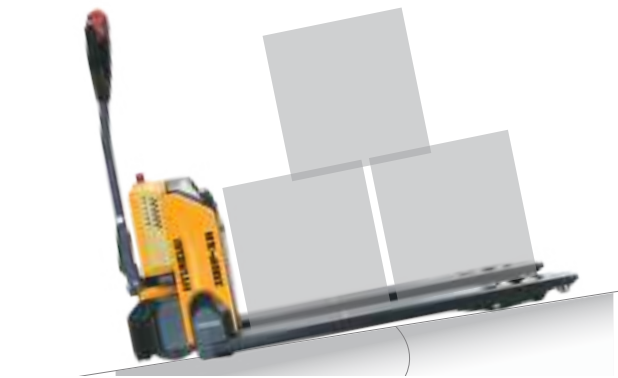

The 12/15/20EP-XB series trucks have great performance on ramps even when they are fully loaded regardless their economic position-ing, each truck based on its performance level can climb on sufficient level of ramp, therefore, every customer can select the truck with consideration of particular working environment.

Model	12EP-XB	15EP-XB	20EP-XB
Max. grade ability laden	4%	6%	7%
Max. grade ability unladen	16%	16%	16%

The frame of truck is surrounded by stamped steel elements making the truck looking different and also ensuring the protection of components for 12EP-XB and 15EP-XB.



Forks of the truck with shape for easy entrance and exit from pallets for 15EP-XB and 20EP-XB. Full length double sided C-shape reinforcements of forks significantly increase strength and rigidity of frame.



Strong steel apron protects the operator's feet during work and secures the truck's components from collisions with objects.



20EP-XB

Maintenance Friendly

Drive motor with intelligent Curtis control



For the pallet trucks there are no hoses or pipes used in the hydraulic lifting circuit which significantly improves **reliability** and reduces the amount of potential problems related to leakages through connectors or their seals.

The trucks are equipped with Curtis controllers, CAN-bus technology makes the diagnostic and troubleshooting easier. The use of proved and certified components helps to ensure the conformity to international safety standards with all the supporting documents available as required by law.



Capacity

	Ready	Min Volt	Min Volt
	24.50V	0mV	0mV
	0.00A	Avg Volt	Communication
		0.0mV	Normal

Realtime

Rated capacity	60.0 Ah	Wh(Current)	0.0	Wh	<input type="button" value="Reset"/>
Discharge cycle Times	...	Discharge cycle Times	...		

Other

Name	Value	Units
Cell Temp1	25.3	°C
Cell Temp1	25.1	°C
SOC	45	1/255
Power Temp	27.1	°C
Envir Temp	32.2	°C
Cell Volt Alarm	none	
Total Volt Alarm	none	
Current Alarm	none	
Temp Alarm	none	
Balance Alarm	none	

Volt

Name	Value	Units
Cell	3,507	mV
Total	24.5	V
Current	0.0	A
Run(Wh)	0	Wh

Each battery can be diagnosed via CAN connection with help of special software tool, the software can provide information about the battery condition such as balance of cells, amount of charging/discharging cycles, current, energy consumption, temperature, charging/discharging parameters, voltage of every cell, faults and alarms, settings of timing for automatic turn off.



20EP-XB

Standard configuration or options

	12EP-XB	15EP-XB	20EP-XB
Standard battery	Li-ion 24V / 20Ah	Li-ion 24V / 20Ah	Li-ion 48V / 20Ah
Li-ion battery 24V / 20Ah	S	S	—
Li-ion battery 24V / 36Ah	O	O	—
Standard charger	24V / 5A	24V / 5A	48V / 9A
Li-ion charger 24V / 5Ah	S	S	—
Li-ion charger 24V / 8Ah	With optional battery only	O	—
Li-ion charger 24V / 12Ah (CE only)	With 36Ah battery only	With 36Ah battery only	—
BMS	S	S	—
CAN-communication	S	S	S
Speed reduction at turning	O	O	S
Vertical drivr / Pin wheel	S	S	S
Fast battery replacement	S	S	S
Entry roller	S	S	S
Single fork rollers	S	S	S
Tandem fork rollers	O	O	O
On-board charger	—	—	—
Stability castors	O	O	S
High traction drive wheel tyre	O	O	—
Fork length 800 / 900 / 1,000mm	O	O	O
Load backrest (42 / 48 / 60°)	—	O	O
Pin code access with LCD display on tiller	O	S	S
RFID access	O	O	S
LED Indicators on tiller	S	—	—
	S = Standard	O = Optional	— = Not available

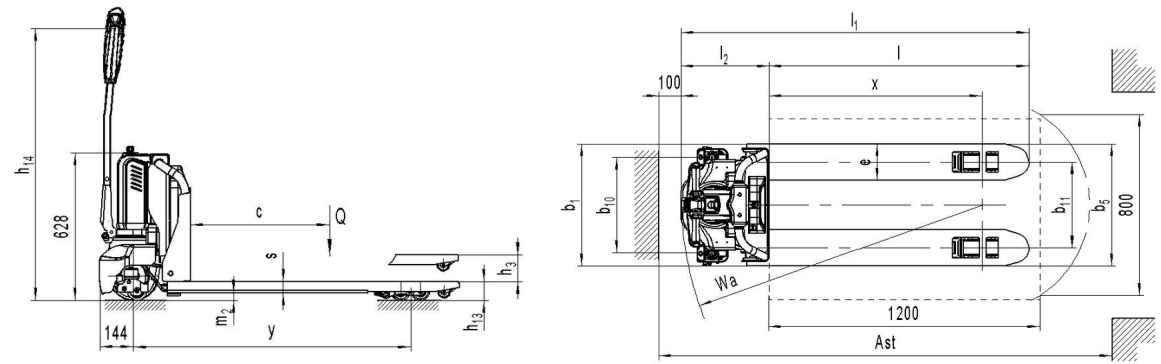

Type sheet for industrial truck acc. to VDI 2198

Identification

1.2	Manufacturer's type designation		12EP-XB
1.3	Drive		Battery
1.4	Operator type		Pedestrian
1.5	Load capacity / rated load	Q (t)	1.2
1.6	Load centre distance	c (mm)	600
1.8	Load distance, centre of drive axle to fork	x (mm)	942
1.9	Wheelbase	y (mm)	1,185

Weights

2.1	Service weight	kg	124	129
2.2	Axle loading, laden front / rear	kg	355 / 972	425 / 908
2.3	Axle loading, unladen front / rear	kg	101 / 27	106 / 27

Wheels, Chassis

3.1	Tires		Polyurethane (PU)	
3.2	Tire size, front	Øx w (mm)	Ø 210×70	
3.3	Tire size, rear	Øx w (mm)	Ø 80×93 (Ø 80×70)	
3.4	Additional wheels (dimensions)	Øx w (mm)	Ø- / 80×30	
3.5	Wheels, number front / rear (x=driven wheels)		1x / 2(1x / 4) or 1x + 2 / 2(1x + 2 / 4)	
3.6	Tread, front	b10 (mm)	- / 430	
3.7	Tread, rear	b11 (mm)	380	525

Basic Dimensions

4.4	Lift	h3 (mm)	115	
4.9	Height of tiller in drive position min. / max.	h14 (mm)	700 / 1,160	
4.15	Height, lowered	h13 (mm)	80	
4.19	Overall length	l1 (mm)	1,537	
4.20	Length to face of forks	l2 (mm)	387	
4.21	Overall width	b1 (mm)	540	685
4.22	Fork dimensions	s/e/l (mm)	48 / 160 / 1,150	
4.25	Width across forks	b5 (mm)	540	685
4.32	Ground clearance, centre of wheelbase	m2 (mm)	32	
4.34	Aisle width for pallets 800×1,200 lengthways (200mm safe distance)	Ast (mm)	2,007	
4.35	Turning radius	Wa (mm)	1,337	

Performance Data

5.1	Travel speed, laden / unladen	km/h	4.6 / 4.8	
5.2	Lift speed, laden / unladen	m/s	0.031 / 0.037	
5.3	Lowering speed, laden / unladen	m/s	0.069 / 0.051	
5.8	Max. gradeability, laden / unladen	%	4 / 16	
5.10	Service brake		Electromagnetic	

E-Motor

6.1	Drive motor rating S2 60min	kW	0.65	
6.2	Lift motor rating at S3 10%	kW	0.50	
6.3	Battery acc. to DIN 43531 / 35 / 36 A, B, C, no		N/A	
6.4	Battery voltage, nominal capacity K5	V / Ah	24 / 15	
6.5	Battery weight	kg	4.4	
6.6	Energy consumption acc. to VDI cycle	kWh/h	0.14	

Other Details

8.1	Type of drive control		DC speed control	
8.4	Sound level at driver's ear acc. to EN 12053	dB(A)	<70	

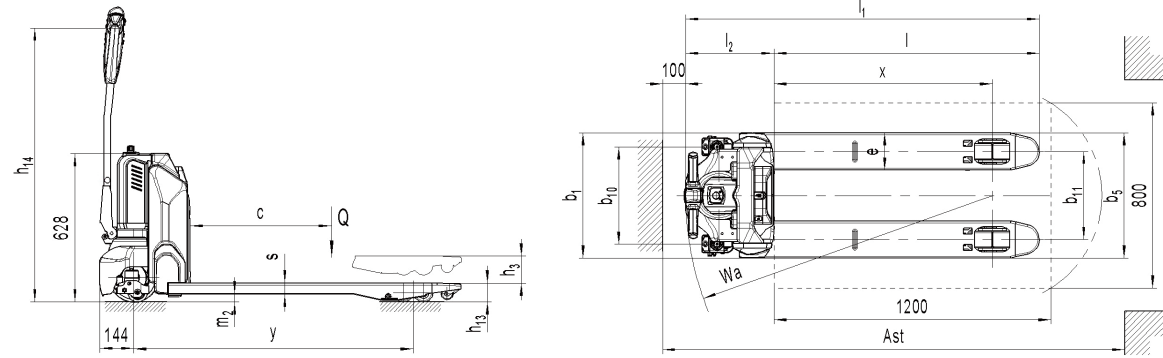

Type sheet for industrial truck acc. to VDI 2198

Identification						
1.2	Manufacturer's type designation		15EP-XB	20EP-XB		
1.3	Drive		Battery			
1.4	Operator type		Pedestrian			
1.5	Load capacity / rated load	Q (t)	1.5	2.0		
1.6	Load centre distance	c (mm)	600			
1.8	Load distance, centre of drive axle to fork	x (mm)	947	951		
1.9	Wheelbase	y (mm)	1,185	1,189		
Weights						
2.1	Service weight	kg	123	126	149	153
2.2	Axle loading, laden front / rear	kg	623 / 1,000	626 / 1,000	621 / 1,528	625 / 1,528
2.3	Axle loading, unladen front / rear	kg	96 / 27	99 / 27	115 / 34	119 / 34
Wheels, Chassis						
3.1	Tires		Polyurethane (PU)			
3.2	Tire size, front	Øx w (mm)	Ø 210×70			
3.3	Tire size, rear	Øx w (mm)	Ø 80×93 (Ø 80×70)			
3.4	Additional wheels (dimensions)	Øx w (mm)	Ø 80×30			
3.5	Wheels, number front / rear (x=driven wheels)		1x/ 2(1x/ 4) or 1x +2/ 2(1x +2/ 4)			
3.6	Tread, front	b10 (mm)	430			
3.7	Tread, rear	b11 (mm)	380	525	380	525
Basic Dimensions						
4.4	Lift	h3 (mm)	115			
4.9	Height of tiller in drive position min. / max.	h14 (mm)	700 / 1,160			
4.15	Height, lowered	h13 (mm)	80			
4.19	Overall length	l1 (mm)	1,530	1,536		
4.20	Length to face of forks	l2 (mm)	380	386		
4.21	Overall width	b1 (mm)	540	685	540	685
4.22	Fork dimensions	s/e/l (mm)	47 / 160 / 1,150			
4.25	Width across forks	b5 (mm)	540	685	540	685
4.32	Ground clearance, centre of wheelbase	m2 (mm)	33			
4.34	Aisle width for pallets 800×1,200 lengthways (200mm safe distance)	Ast (mm)	2,000	2,006		
4.35	Turning radius	Wa (mm)	1,330	1,336		
Performance Data						
5.1	Travel speed, laden / unladen	km/h	4.6 / 4.8	4.8 / 5.2		
5.2	Lift speed, laden / unladen	m/s	0.020 / 0.025	0.017 / 0.022		
5.3	Lowering speed, laden / unladen	m/s	0.05 / 0.04	0.05 / 0.03		
5.8	Max. gradeability, laden / unladen	%	6 / 16	7 / 16		
5.10	Service brake		Electromagnetic			
E-Motor						
6.1	Drive motor rating S2 60min	kW	0.65	0.75		
6.2	Lift motor rating at S3 10%	kW	0.50	0.8		
6.3	Battery acc. to DIN 43531 / 35 / 36 A, B, C, no		N/A			
6.4	Battery voltage, nominal capacity K5	V / Ah	24 / 20 (24/30;24/36)	48 / 20		
6.5	Battery weight	kg	4.6	7.5		
6.6	Energy consumption acc. to VDI cycle	kWh/h	0.22	0.18		
Other Details						
8.1	Type of drive control		DC speed control			
8.4	Sound level at driver's ear acc. to EN 12053	dB(A)	<70			

16EP-X/20EP-X/25EP-X

Electric pedestrian power pallet truck with capacities of 1,600/2,000/2,500kg

- Ergonomic, compact and safe long tiller design
- Reliable and strong chassis
- Powerful, maintenance free German AC power train
- Core components from top quality brands

INTRODUCTION

The 16/20/25EP-X series is the first choice for truck loading and unloading as well for universal transportation on short distances with capacities from 1,600kg up to 2,500kg. With the short chassis length (16EP-X) the truck is tailored to operate in confined areas. With its high-quality and state of the art top-brand components and technologies, the truck competes with leading well-known brands in the market.



16EP-X

Top brand qualified components

Using high quality core components:

- Reliable multifunctional REMA tiller with ergonomic contactless rocker-switches
- Top quality schabmueller AC drive motor
- KORDEL gearbox
- Intorque brake
- Wicke drive wheel
- Curtis controller

The parts used reduce high service costs and give you the performance and reliability which is required for the most demanding harsh loading and unloading operations.

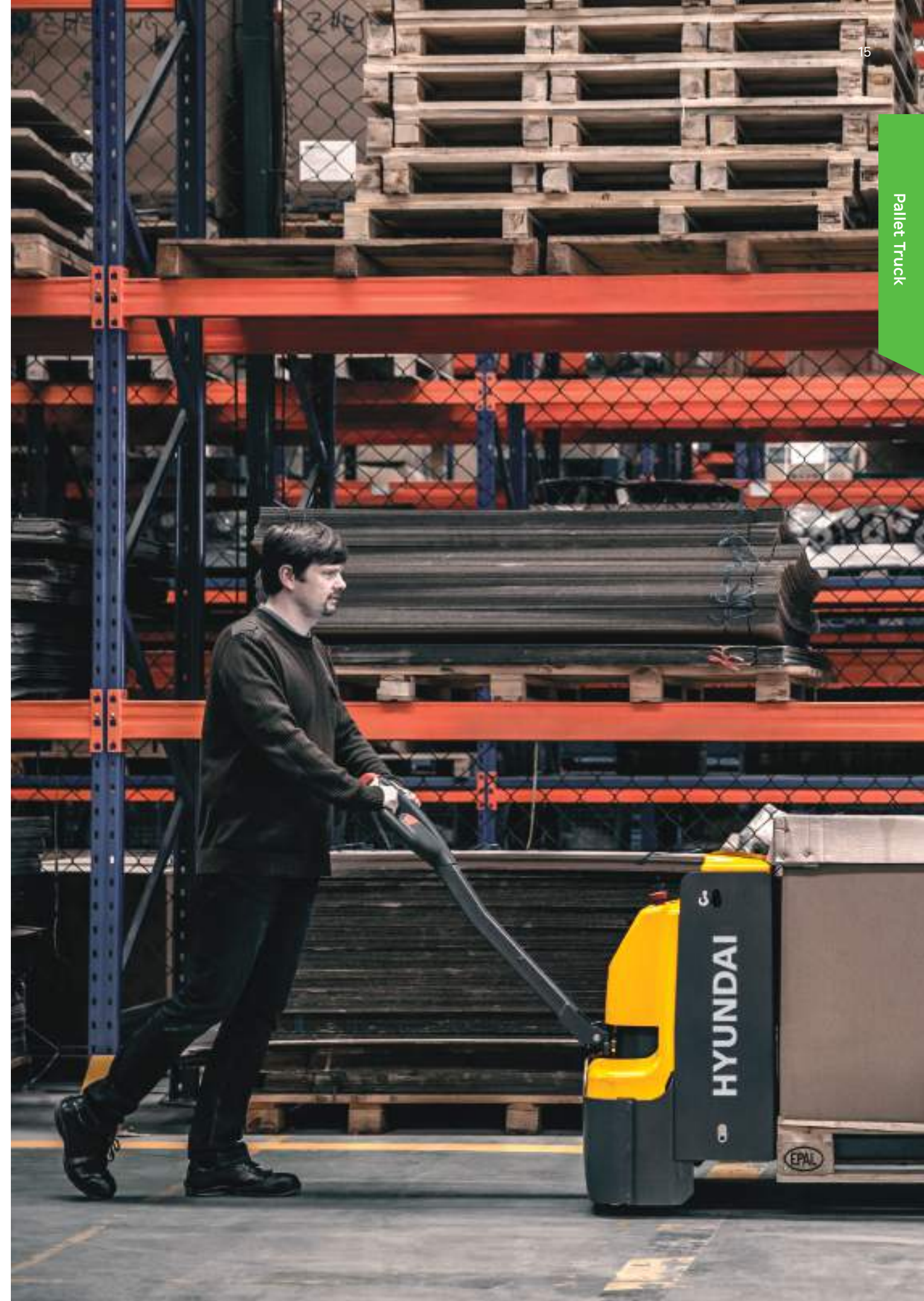

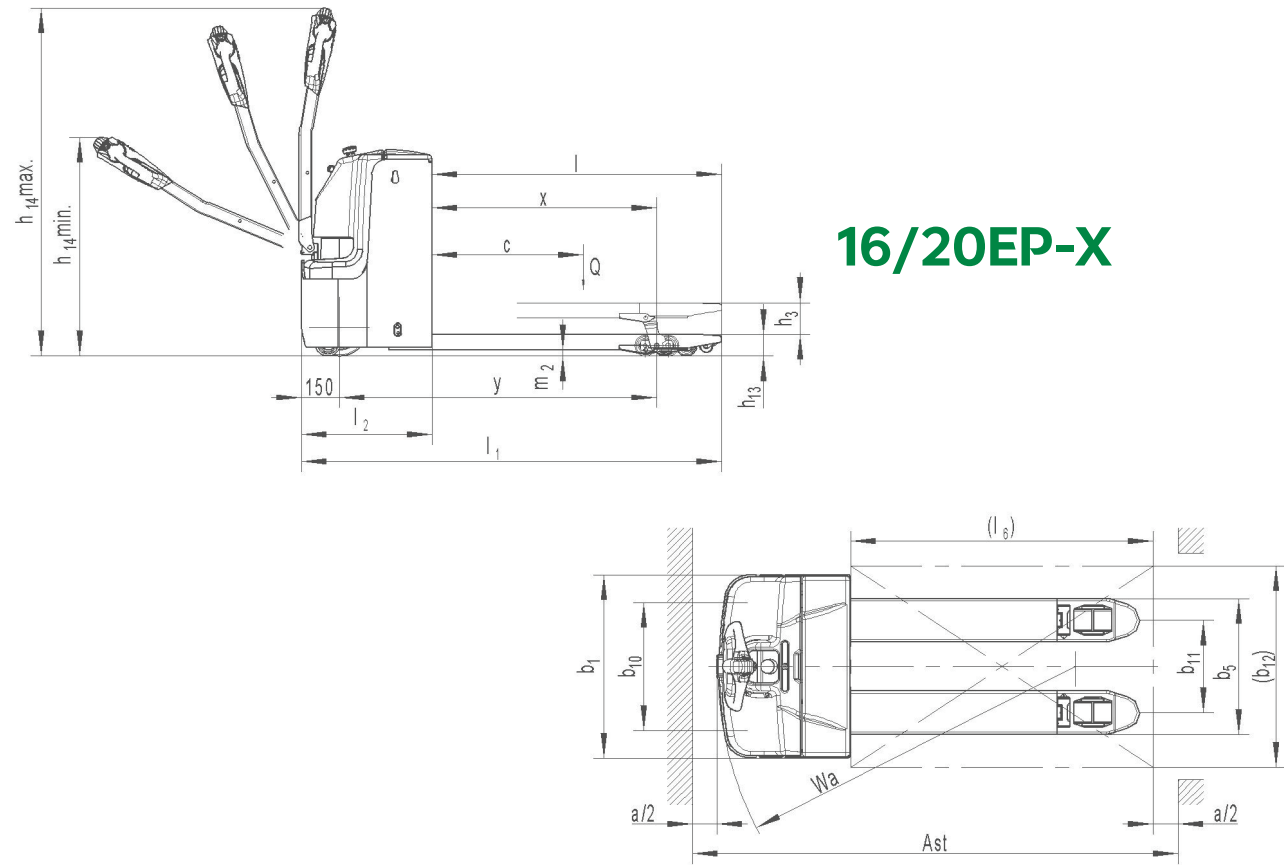

16/20EP-X

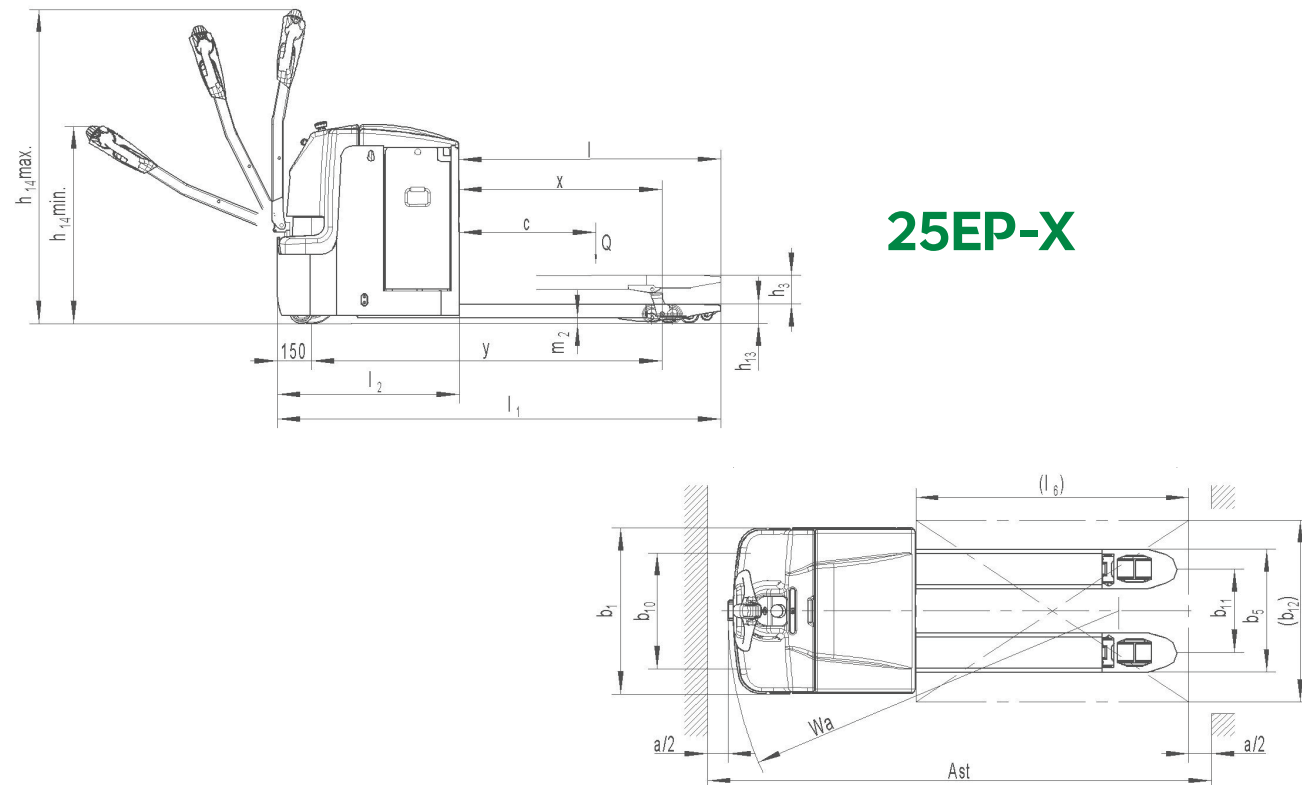

25EP-X

Type sheet for industrial truck acc. to VDI 2198

Identification					
1.2	Manufacturer's type designation		16EP-X	20EP-X	25EP-X
1.3	Drive		Battery		
1.4	Operator type		Pedestrian		
1.5	Load capacity / rated load	Q (t)	1.6	2.0	2.5
1.6	Load centre distance	c (mm)	600		
1.8	Load distance, centre of drive axle to fork	x (mm)	892		
1.9	Wheelbase	y (mm)	1,261	1,327	1,541
Weights					
2.1	Service weight	kg	445	535	720
2.2	Axle loading, laden front / rear	kg	715 / 1,330	855 / 1,680	1,040 / 2,200
2.3	Axle loading, unladen front / rear	kg	345 / 100	415 / 120	540 / 200
Wheels, Chassis					
3.1	Tires		Polyurethane (PU)		
3.2	Tire size, front	Øx w (mm)	Ø 230×70		
3.3	Tire size, rear	Øx w (mm)	Ø 84×84		
3.4	Additional wheels (dimensions)	Øx w (mm)	Ø 100×40		
3.5	Wheels, number front/rear (x=driven wheels)		1x+2/4		
3.6	Tread, front	b10 (mm)	510		
3.7	Tread, rear	b11 (mm)	367 / 512		
Basic Dimensions					
4.4	Lift	h3 (mm)	120		
4.9	Height of tiller in drive position min. / max.	h14 (mm)	800 / 1,335		
4.15	Height, lowered	h13 (mm)	85		
4.19	Overall length	l1 (mm)	1,670	1,735	1,950
4.20	Length to face of forks	l2 (mm)	520	595	810
4.21	Overall width	b1 (mm)	729		
4.22	Fork dimensions	s/e/l (mm)	60 / 173 / 1,150		
4.25	Width across forks	b5 (mm)	540 / 685		
4.32	Ground clearance, centre of wheelbase	m2 (mm)	25		
4.33	Aisle width for pallets 1,000×1,200 crossways	Ast (mm)	1,885	1,955	2,175
4.34	Aisle width for pallets 800×1,200 lengthways	Ast (mm)	1,935	2,005	2,225
4.35	Turning radius	Wa (mm)	1,440	1,490	1,750
Performance Data					
5.1	Travel speed, laden / unladen	km/h	5.7 / 6.0	5.7 / 6.0	5.5 / 6.0
5.2	Lift speed, laden / unladen	m/s	0.025 / 0.035	0.022 / 0.030	0.035 / 0.045
5.3	Lowering speed, laden / unladen	m/s	0.035 / 0.030	0.035 / 0.035	0.040 / 0.040
5.8	Max. gradeability, laden / unladen	%	8 / 15		
5.10	Service brake		Electromagnetic		
E-Motor					
6.1	Drive motor rating S2 60min	kW	1.3	1.3	1.7
6.2	Lift motor rating at S3 10%	kW	0.8	0.8	2.2
6.3	Battery acc. to DIN 43531 / 35 / 36 A, B, C, no		2VBS	2PZS	3PZS
6.4	Battery voltage, nominal capacity K5	V / Ah	24 / 160	24 / 210	24 / 350
6.5	Battery weight	kg	150	215	285
6.6	Energy consumption acc. to VDI cycle	kWh/h	0.44	0.39	0.92
Other Details					
8.1	Type of drive control		AC speed control		
8.4	Sound level at driver's ear acc. to EN 12053	dB(A)	67	69	65

20/25EPR-X

The model range of powered pallet truck includes machines with capacities of 2,000kg and 2,500kg.

INTRODUCTION

The truck designed to be used with high efficiency even during their multi-shift operation. The configuration of the trucks allows you to get more powerful and productive units thanks to its increased speed and different options of batteries, including Lithium solutions.

ADVANTAGES

- The new model range of short-tiller trucks has combined all the experience over past years. By using of the most advanced solutions and top level components, the new range is ready to provide the top level of performance to its users.
- During the design stage, several priorities and various details were considered and verified such as improvement of the service life and performance of our trucks, easy maintenance as well as confirmation of interchangeability of components not only within model range, but also with other ranges of Hyundai products.
- The experience of Hyundai products shows that the use of top brand components from well-know suppliers not only helps to improve reliability, but also gain trust from our customers and put the products to new level. That is why nearly all key components used for the model range are coming from famous brands with rich experience in material handling industry.



Powerful AC-drive unit from the global industry leaders: the AC driving motor designed and produced by Schabmuller comes together with the top quality ZF gearbox and it is equipped with Intorq electromagnetic brake. The drive unit can provide the drive speed up to 8km/h. The use of top level quality drive wheel from German manufacturers Rader Vogel or Wicke helps to ensure the long life time of pu tires.



The integrated design of operator's platform and protective arms as well as totally new internal structure allows to ensure the smallest body length and provide extremely low turning radius among competitors. Together with this, the suspension system for the platform helps to provide the high level of comfort to operators.



The use of apron with 8mm thickness allows to ensure the robustness of chassis and its strength even in case of collision against objects. The strong battery cover made out of steel helps to provide a high level of strength for this part.



Rema tiller delivers high level of ergonomics as well as reliability of control system. In addition, the tiller ensures a long life-time thanks to the contactless rocker switches designed for lifting/lowering function.



The Curtis controller provides customers with reliable and flexible high performance control system solutions.



The option of PIN-code panel access, which works not only with PIN-code but also with access cards (RFID), can significantly simplify the procedure of access limitation for the fleet which may be used by more than one operator. The option of built-in charger may help to simplify charging processes for the customers using the trucks not so intensively (without multi-shift operation connected with necessity of battery replacement).



The model range can be equipped with the option of Electric Power Steering (EPS) which delivers precise and fast control for the position of steering wheel and has a high level of reliability as well as safety according to official standards.



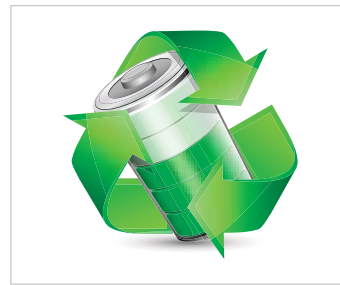

The option of side battery replacement allows customers to use the truck with multi-shift operation and not to waste time on complicated procedure of battery replacement through the top. With help of specially designed trolley, the batteries can be replaced fast and effortlessly.

The trucks can be equipped with Aquamatic, a system for rapidly refilling distilled water in Lead-acid batteries. The 2-ton pallet truck can be optionally equipped with the battery under 3VBS standard, which helps to reduce the length of the original truck and make it more compact (the standard battery is 2PzS)

The model range can be equipped with Lithium batteries. The use of Lithium solution from Hyundai products will allow you to enjoy benefits of Lithium technology such as Fast charging, Opportunity charging, Maintenance free, Environmental-friendly, Smart Diagnosis of battery status, Lower cost of Total Ownership with long service life.

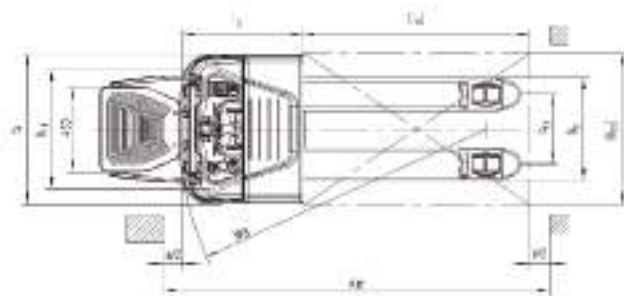
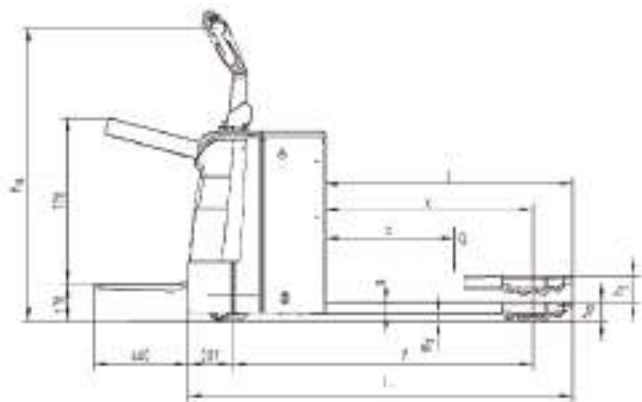

Type sheet for industrial truck acc. to VDI 2198

Identification		20EPR-X	25EPR-X	
1.2	Manufacturer's type designation			
1.3	Drive	Battery		
1.4	Operator type	Pedestrian / Stand		
1.5	Load capacity / rated load	Q (t)	2.0	2.5
1.6	Load centre distance	c (mm)	600	600
1.8	Load distance, centre of drive axle to fork	x (mm)	892 ¹⁾	892 ¹⁾
1.9	Wheelbase	y (mm)	1,330 ¹⁾²⁾	1,435 ¹⁾
Weights				
2.1	Service weight	kg	620	770
2.2	Axle loading, laden front / rear	kg	1,110 / 1,510	1,370 / 1,900
2.3	Axle loading, unladen front / rear	kg	500 / 120	610 / 160
Wheels, Chassis				
3.1	Tires		Polyurethane (PU)	
3.2	Tire size, front	Øx w (mm)	Ø 230x70	
3.3	Tire size, rear	Øx w (mm)	Ø 84x84	
3.4	Additional wheels (dimensions)	Øx w (mm)	Ø 100x40	
3.5	Wheels, number front / rear (x=driven wheels)		1x+2/4	
3.6	Tread, front	b10 (mm)	540	
3.7	Tread, rear	b11 (mm)	367 / 512	
Basic Dimensions				
4.4	Lift	h3 (mm)	120	
4.9	Height of tiller in drive position min. / max.	h14 (mm)	950 / 1,350	
4.15	Height, lowered	h13 (mm)	85	
4.19	Overall length	l1 (mm)	1,790 ²⁾³⁾	1,895
4.20	Length to face of forks	l2 (mm)	640 ²⁾³⁾	745 ³⁾
4.21	Overall width	b1 (mm)	790	
4.22	Fork dimensions	s/e/l (mm)	55 / 173 / 1,150	
4.25	Width across forks	b5 (mm)	540 / 685	
4.32	Ground clearance, centre of wheelbase	m2 (mm)	30	
4.33	Aisle width for pallets 1,000 x 1,200 crossways	Ast (mm)	2,400 ²⁾³⁾	2,505 ³⁾
4.34	Aisle width for pallets 800 x 1,200 lengthways	Ast (mm)	2,290 ²⁾³⁾	2,395 ³⁾
4.35	Turning radius	Wa (mm)	1,585 ²⁾³⁾	1,690 ³⁾
Performance Data				
5.1	Travel speed, laden / unladen	km/h	7.5/8.0	6.0 / 7.0
5.2	Lift speed, laden / unladen	m/s	0.025 / 0.030	0.035 / 0.045
5.3	Lowering speed, laden / unladen	m/s	0.030 / 0.025	0.045 / 0.050
5.8	Max. gradeability, laden / unladen	%	8 / 15	
5.10	Service brake		Electromagnetic	
E-Motor				
6.1	Drive motor rating S2 60min	kW	1.4	
6.2	Lift motor rating at S3 10%	kW	0.8	2.2
6.3	Battery acc. to DIN 43531 / 35 / 36 A, B, C, no		N/A	N/A
6.4	Battery voltage, nominal capacity K5	V / Ah	24 / 160-210	24 / 270-350
6.5	Battery weight	kg	155-200	235-285
6.6	Energy consumption acc. to VDI cycle	kWh/h	0.36	0.90
Other Details				
8.1	Type of drive control		AC speed control	
8.4	Sound level at driver's ear acc. to EN 12053	dB (A)	69	

1) Load section lowered: +65mm 2)With side battery removal: +30mm 3)With unfolded platform: +440mm

27/36 EPR-X

The model range of powered pallet truck includes machines with capacities of 2,000kg and 2,500kg.

Hyundai EPR walkie riders make moving pallets, picking orders, and navigating loading docks quick and easy. They do it all with greater operator comfort and control and advanced features that not only drive up productivity but drive down costs. And with its rugged construction, the 27/36EPR excels in even the most punishing of environments to deliver years of dependable service.

Outstanding ergonomics. Fast operating speeds. Superior maneuverability. Simplified servicing. It all adds up to the best value on the market. So, get more in, around, and out of your warehouse with EPR walkie rider.



Generous platform

The key to greater productivity over long workdays is to maximize operator comfort and control. The EPR platform offers a large operating space that puts the focus on the operator. It features a soft mat surface to reduce fatigue and a sturdy bumper for greater protection navigating tight spaces and narrow aisles.



Open battery compartment

350.5mm open battery compartment ready for wide range of industrial batteries, flexible for different battery dimensions.



Heavy duty backrest

The heavy duty load backrest provides a strong barrier between the operator and the load. To reduce downtime, it features a unique tilt down design that makes battery change out faster and simpler. To further cut downtime, optional battery rollers are available to make battery change out even faster.



Tray

The tray gives the right place for your work equipment.

The 27/36 EPR-X brings you even more advantages

- The fast charging, optional Li-ion battery is maintenance free and offers extended working time.
- Powerful, maintenance-free AC drive motor delivers high 14km/h (unloaded) and 11km/h (loaded) travel speeds.
- Proven Curtis Controller offers reliable performance while delivering smooth speed and torque control.
- Dual butterfly-style thumb controls for precise handling.
- Crawl Button assures safe and easy operation within confined spaces.
- The handy work tray provides valuable storage for a variety of material to keep operators working.
- The open battery compartment accepts a wide array of batteries.
- Safety is enhanced with dual stability casters and an emergency power disconnect.



Ergonomically designed tiller

The German engineered tiller features a robust metal design for enhanced durability. It is engineered to provide maximum operator comfort and control, allowing for precise handling with less fatigue while both riding and walking. For added safety, it features a conveniently positioned horn and belly button.



Optional jog button

This innovative feature allows the operator to walk beside the truck making order picking more convenient while maintaining confident control of the machine. The additional side tracker assures travelling in the tiller direction to increase productivity while the coast mode allows for slow coasting.



Comfortable grab bar

The grab bar features electronic controls ergonomically placed to make operation effortless. Beyond adding greater stability for the operator, the grab bar is coated for additional comfort throughout the workday. The goal is to provide operators with the confidence they need to move pallets more quickly.



Durability and Functionality

One of the strongest and most solid chassis in the market, the best solution for the toughest application in the market! The easy fork adjustment as well as access to the main components ensures excellent serviceability. The rigid strength of the forks provides maximum durability.

Fork tip configuration

		27EPR-X						36EPR-X		
		(mm)								
Nominal fork length	(mm)	915	1,067	1,220	1,372	1,525	2,440	2,135	2,362	2,440
Actual fork length	l (mm)	908	1,060	1,213	1,365	1,518	2,433	2,128	2,355	2,433
Overall length	l1 (mm)	2,025	2,177	2,330	2,482	2,635	3,550	127.8	136.8	3550
Wheelbase (raised)	y (mm)	1,305	1,458	1,615	1,765	1,917	2,835	2,130	2,130	2,130
Load wheel distance	x (mm)	723	875	1,028	1,180	1,333	2,248	1,567	1,567	1,567
Fork tip length	1-x (mm)	185	185	185	185	185	185	560	795	864
Turning radius (raised)	Wa (mm)	1,840	1,992	2,145	2,297	2,450	3,365	2,660	2,660	2,660
Fork width	c (mm)	230						255		

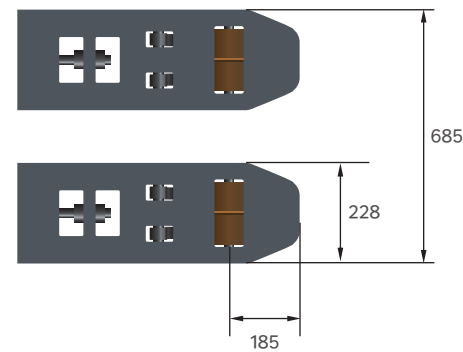
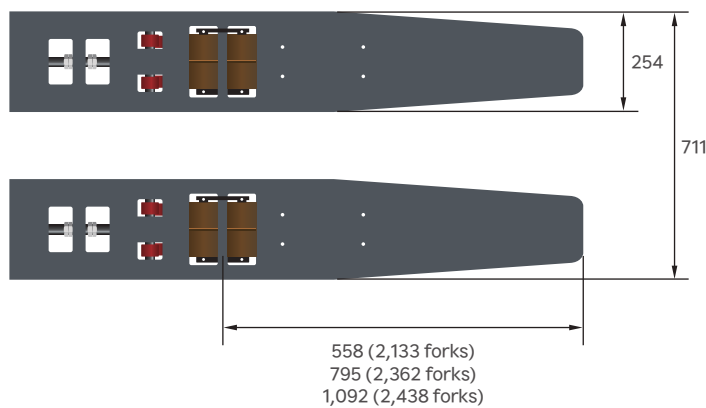
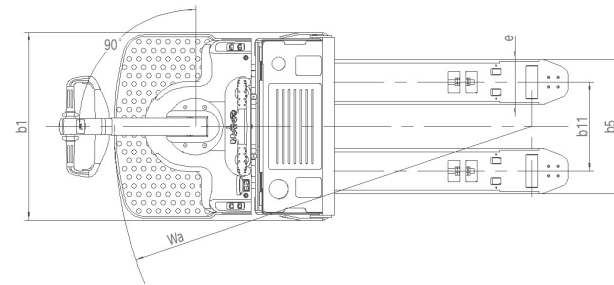
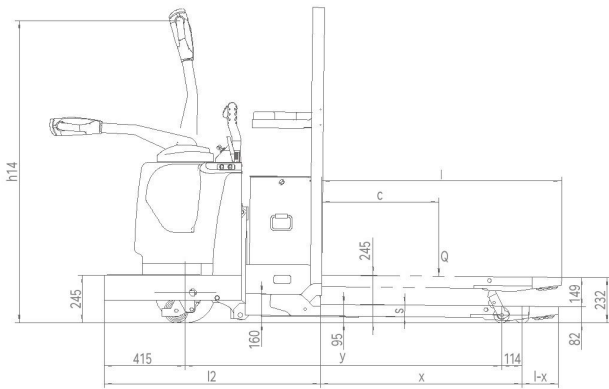

Type sheet for industrial truck acc. to VDI 2198

Identification

1.2	Manufacturer's type designation		27EPR-X	36EPR-X
1.3	Drive		Battery	
1.4	Operator type		Pedestrian	
1.5	Load Capacity / rated load	Q (t)	2.7	3.6
1.6	Load centre distance	c (mm)	600	1,220
1.8	Load distance, centre of drive axle to fork	x (mm)	1,035	1,345
1.9	Wheelbase	y (mm)	1,615	2,130

Weights

2.1	Service weight	kg	1,070	1,150
2.2	Axle loading, laden front / rear	kg	1,390 / 2,380	1,300 / 3,470
2.3	Axle loading, unladen front / rear	kg	830 / 240	920 / 250

Wheels, Chassis

3.1	Tires		Polyurethane (PU)	
3.2	Tire size, front	Ø x w (mm)	Ø 310 x 105	
3.3	Tire size, rear	Ø x w (mm)	Ø 82 x 82	Ø 82 x 70
3.4	Additional wheels (dimensions)	Ø x w (mm)	Ø 125 x 60	
3.5	Wheels, number front / rear (x=driven wheels)		1x + 2 / 4	1x+1 / 8
3.6	Tread, front	b10 (mm)	455	
3.7	Tread, rear	b11 (mm)	560 / 685	585 / 710

Basic Dimensions

4.4	Lift	h3 (mm)	150	
4.9	Height of tiller in drive position min. / max.	h14 (mm)	880 / 1,550	
4.15	Height, lowered	h13 (mm)	83	
4.19	Overall length	l1 (mm)	2,330	3,350
4.20	Length to face of forks	l2 (mm)	1,095	
4.21	Overall width	b1 (mm)	940 / 960	
4.22	Fork dimensions	s/e/1 (mm)	60 / 230 / 1,220	60 / 255 / 2,440
4.25	Width across forks	b5 (mm)	560 / 685	585 / 710
4.32	Ground clearance, centre of wheelbase	m2 (mm)	25	
4.33	Aisle width for pallets 1,000 X 1,200 crossways	Ast (mm)	2,700	3,900
4.35	Turning radius	Wa (mm)	2,145	2,660

Performance Data

5.1	Travel speed, laden / unladen	km/h	11 / 14	9.5 / 12
5.2	Lift speed, laden / unladen	mm/s	38 / 49	30 / 40
5.3	Lowering speed, laden / unladen	mm/s	55 / 50	45 / 42
5.8	Max. gradeability, laden / unladen	%	8 / 15	6 / 15
5.10	Service brake		Electromagnetic	

E-Motor

6.1	Drive motor rating S2 60min	kW	3.8	
6.2	Lift motor rating at S3 I0%	kW	2.2	
6.3	Battery acc. to DIN 43531 / 35 / 36 A, B, C, no		no, 5PZS	
6.4	Battery voltage, nominal capacity K5	V/Ah	24 / 350	
6.5	Battery weight	kg	320	
6.5	Energy consumption acc. to VDI cycle	kWh/h	1.83	

Other Details

8.1	Type of drive control		AC-Speed control	
8.4	Sound level at driver's ear acc. to EN 12053	dB (A)	69	
8.6	Steering		Mechanical	

20/25/30 HP-X

The model range of pallet truck includes machines with capacities of 2,000 / 2,500 / 3,000kg

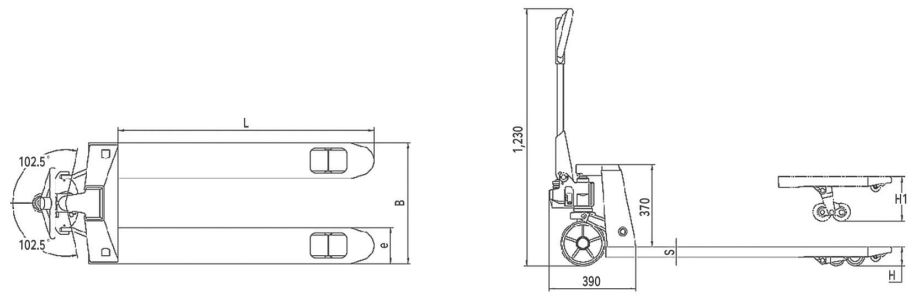

Hand Pallet truck		20HP-X		25HP-X		30HP-X	
Item / Type							
Capacity	Q (kg)	2,000		2,500		3,000	
Min. fork height	H (mm)	85	75	85	75	85	75
Min. fork height	H ₁ (mm)	200	190	200	190	200	190
Steering wheel	(mm)	Ø 200×50	Ø 180×50	Ø 200×50	Ø 180×50	Ø 200×50	Ø 180×50
Load roller single	(mm)	Ø 80×93	Ø 74×93	Ø 80×93	Ø 74×93	Ø 80×93	Ø 74×93
Load roller tandem	(mm)	Ø 80×70	Ø 74×70	Ø 80×70	Ø 74×70	Ø 80×70	Ø 74×70
Size of fork	e*s (mm)	160×50				160×60	
Width overall forks	B (mm)	540 / 685					
Fork length	L (mm)	1,150 / 1,220					

Conforms to EN 1757-2

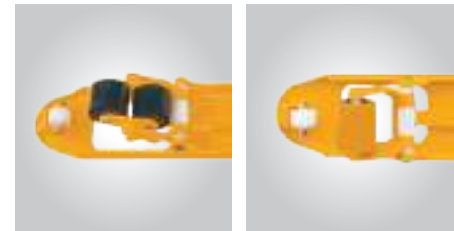

Option of single and tandem fork rollers. Additional entry and exit fork rollers guarantees for maximum stability and safety for transporting goods on slopes.



Option of different coating material for both steering wheel and fork rollers.

- Polyurethane - Ideal for delicate floors with hard wearing and non-marking property, quiet and durable.
- Nylon - low drag efforts, high resistance to chemicals, non-marking, preferred in food, fishing and chemical industries with smooth level floors.
- Rubber - Best choice for quiet and durable demands, ideal for smooth and rough floors.



Excellent galvanized whole casting hydraulic pump, robust and durable, with fine control of lowering speed and overload valve, low routine maintenance.

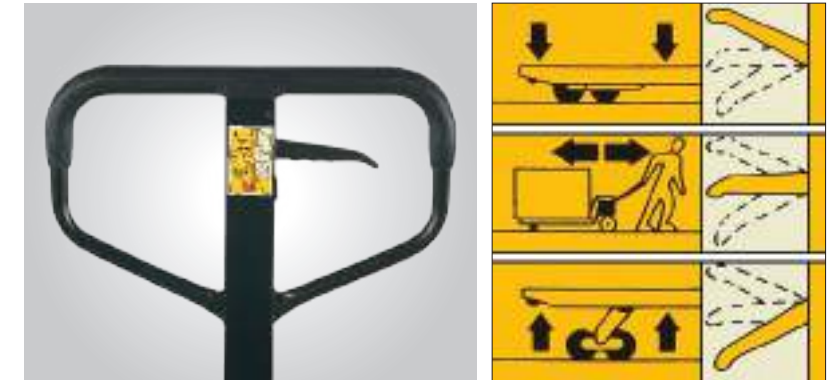

Ergonomically designed handle with comfortable rubber grip allows the optimized safety as well as comfortable. Three position operational handle lever for lifting, transporting and lowering purposes.

- Lower Position - to lower load, pull up the finger tip control.
- Neutral position - to place finger tip control in this position during pulling the truck or load.
- Lift Position - to raise load, push down on finger tip control, pump handle to raise the load.

Pallet Stackers



Stacker
- EU standard(Fork-over)

12ES-XB/XN

12ES-XB

• 1.2T Capacity **AGM**

- Perfect for light-duty applications
- Compact & light service weight
- High maneuverability
- Maintenance-free Lead-acid Battery
- Integrated on-board 12A charger
- Ideal for use on mezzanines

12ES-XN

• 1.2T Capacity **Li-ion**

- Perfect for light-duty applications
- Compact & light service weight
- High maneuverability
- Fast-charging Li-ion batteries
- Integrated on-board 25A charger
- Ideal for use on mezzanines
- Ultimate solution for light duty operations

Smart and Ergonomic Tillers

Standard for 12ES-XB and 12EX-XN

RFID card access is optional for 12ES-XB and standard for 12ES-XN

RFID card provides faster access to equipment and ideal for applications when one truck needs to be used by different operators.

Electric Stacker

Vertical Driving in Confined Space



The function of driving with tiller in the **vertical position** helps with work in confined area without sacrificing of safety.

The tiller bar is supported by the air spring which helps to return the tiller to its vertical position without strike in the end point.

For increase of operation comfort and safety the trucks are equipped with speed reduction function in turns.



Smart Design with Compact Size and Perfect Observation

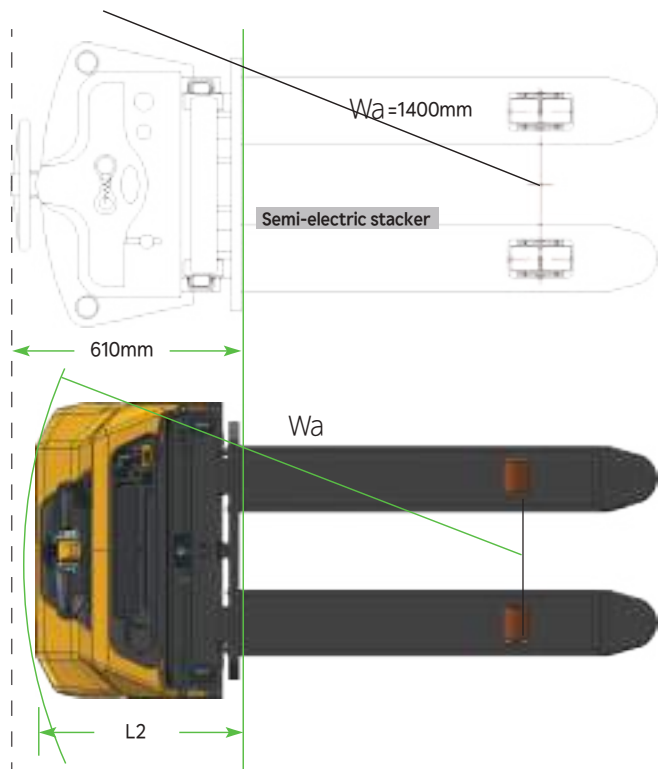

Model	Length(L2)	Turning Radius
12ES-XB/XN	560mm	1,350mm

Our engineers put a lot of efforts to achieve compactness of the trucks in comparison with traditionally used manual and semi-electric products without sacrificing of stability, robustness, safety and operation comfort.

Robustness



Tiller is made out of PA6 30% of glass fiber material, having high strength.

The operator can always clearly see the forks which significantly increases safety of operation.



Wide mast provides perfect observation of forks, the field of view is clear and not interrupted by mast sections, cylinder or chains.



Capacity of 1,200kg with high residual value at maximum height (load center distance 600mm).

Real mast profiles are used for long life-time, no cheap bended solutions used. All directed to maintain performance of the truck during its life-cycle.



Welded forks are used to ensure robustness.

Gradeability Performance

Model	12ES-XB/XN
Max.grade ability laden	5%
Max.grade ability unladen	10%



Maintenance Friendly

Convenient and fast access to any component of the truck, no elements are located in areas difficult to reach. No Special tools are required.



CAN-bus Battery Management System

The BMS of battery controls charging and discharging parameters, working temperature, short circuits, has sleeping mode and is able to turn off the power in case of emergency. Communication with BMS and software adjustment is possible via CAN.



The electric system is using CAN communication protocol increasing reliability of the system.

Capacity

Ready	Min Volt	Max Volt
17.6%	24.50V	0mV
0.00A	Avg Volt	Communication
	0.0mV	Normal

Realtime

Rated capacity	60.0 Ah	Wh(Current)	0.0 Wh	Reset
Discharge cycle ...		Discharge cycle ...		
Times		Times		

Other

Name	Value	Units
Cell Temp1	25.3	°C
Cell Temp1	25.1	°C
SOC	45	1/255
Power Temp	27.1	°C
Envir Temp	32.2	°C
Cell Volt Alarm	none	
Total Volt Alarm	none	
Current Alarm	none	
Temp Alarm	none	
Balance Alarm	none	

Volt

Name	Value	Units
Cell	3,507	mV
Total	24.5	V
Current	0.0	A
Run(Wh)	0	Wh

The software diagnostic tool for Lithium batteries can provide full information about battery's condition and its current status (the above values are for reference only).



12ES-XB
2x12Ah 85Ah (5Hr) AGM maintenance free batteries are used.
2x12 105Ah (5hr).



For 12ES-XB the charger with current 12A is used The standard charging time is 7 hours.



12ES-XN
24V 60Ah Lithium LiFePO4 battery with BMS. Lithium battery has connection terminals with screws and located inside the steel case.



For 12ES-XN the charger with current 25A is used The standard charging time is 2.5hours. Opportunity charging is supported.

The **12ES-XN** stacker is equipped with maintenance-free 24V/60Ah LiFePO4 type Li-ion battery with fast charging and ultra-high number of charging / discharging cycles during life time; opportunity charging feature basically does not limit your operation time. The integrated BMS provides the same features as the BMS for the batteries of pallet trucks(refer to pallet truck section). The on-board charger with 25A current can provide full charge for less than 2.5 hours with great efficiency.

The **12ES-XB** stacker is equipped with 2x12V 85Ah VRLA-AGM maintenance free batteries. Optionally available 2x12V 105Ah batteries for longer operation. The stacker is equipped with 12A on-board charger. The charging time is 7-8 hours, opportunity charging is not available.



12ES-XB/12ES-XN Stacker- EU standard(Fork-over)

Mast table 12ES-XB/12ES-XN

Designation	Lowered mast height h1 (mm)	Free lift height h2 (mm)	Lift height h3 (mm)	Extended mast height h4 (mm)	Lift+fork height h3+h13 (mm)
Single-stage mast	1,930	1,514	1,514	1,930	1,600
	2,330	1,914	1,914	2,330	2,000
Two-stage mast	1,930	-	2,814	3,337	2,900
	2,080	-	3,114	3,637	3,200
	2,280	-	3,514	4,037	3,600

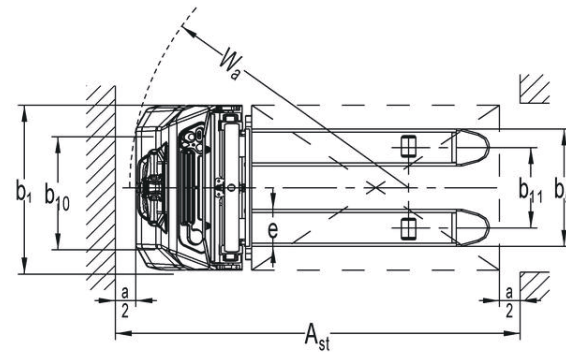
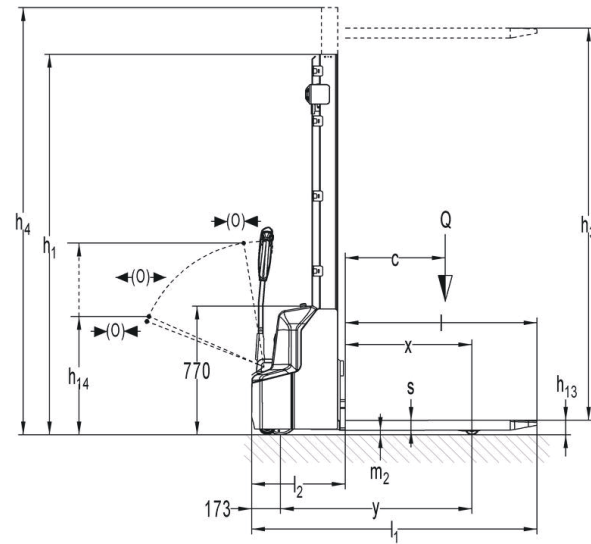

Type sheet for industrial truck acc. to VDI 2198

Identification		12ES-XB	12ES-XN
1.2	Manufacturer's type designation		3,600
1.3	Drive		Battery
1.4	Operator type		Pedestrian
1.5	Load capacity / rated load	Q (t)	1.2
1.6	Load centre distance	c (mm)	600
1.8	Load distance, centre of drive axle to fork	x (mm)	760
1.9	Wheelbase	y (mm)	1,147

Weights			12ES-XB	12ES-XN
2.1	Service weight	kg	620	585
2.2	Axle loading, laden front / rear	kg	580 / 1,240	560 / 1,225
2.3	Axle loading, unladen front / rear	kg	450 / 170	440 / 145

Wheels, Chassis			
3.1	Tires		Polyurethane
3.2	Tire size, front	Øx w (mm)	Ø 210x75
3.3	Tire size, rear	Øx w (mm)	Ø 84x93
3.4	Additional wheels (dimensions)	Øx w (mm)	Ø 100x50
3.5	Wheels, number front / rear (x=driven wheels)		1x + 1/2
3.6	Tread, front	b10 (mm)	550
3.7	Tread, rear	b11 (mm)	400 / 515

Basic Dimensions			
4.2	Lowered mast height	h1 (mm)	2,280
4.3	Free Lift height	h2 (mm)	-
4.4	Lift	h3 (mm)	3,514
4.5	Extended mast height	h4 (mm)	4,037
4.9	Height of tiller in drive position min. / max.	h14 (mm)	710 / 1,150
4.15	Height, lowered	h13 (mm)	86
4.19	Overall length	l1 (mm)	1,710
4.20	Length to face of forks	l2 (mm)	560
4.21	Overall width	b1 (mm)	800
4.22	Fork dimensions	s/e/l (mm)	60 / 180 / 1,150
4.25	Width across forks	b5 (mm)	570 / 685
4.32	Ground clearance, centre of wheelbase	m2 (mm)	26
4.33	Aisle width for pallets 1,000x1,200 crossways	Ast (mm)	2,197
4.34	Aisle width for pallets 800x1,200 lengthways	Ast (mm)	2,145
4.35	Turning radius	Wa (mm)	1,350

Performance Data			
5.1	Travel speed, laden / unladen	km/h	4.5 / 4.7
5.2	Lift speed, laden / unladen	m/s	0.10 / 0.14
5.3	Lowering speed, laden / unladen	m/s	0.13 / 0.126
5.8	Max. gradeability, laden / unladen	%	5 / 10
5.10	Service brake		Electromagnetic

E-Motor			
6.1	Drive motor rating S2 60min	kW	0.65
6.2	Lift motor rating at S3 10%	kW	2.2
6.3	Battery acc. to DIN 43531 / 35 / 36 A, B, C, no		N/A
6.4	Battery voltage, nominal capacity K5	V / Ah	2x12 / 85 ¹⁾ 24 / 60
6.5	Battery weight	kg	2x27 ²⁾ 17
6.6	Energy consumption acc. to VDI cycle	kWh/h	0.8

Other Details			
8.1	Type of drive control		DC
8.4	Sound level at driver's ear acc. to EN 12053	dB(A)	<70

1) 2x12V / 105Ah 2) 2x12V / 106Ah: 2 x 34kg

15ES-XB/XN

Powered stackers

INTRODUCTION

15ES-XB/XN series is an economical long-tiller pallet stacker, with the rated load capacity of 1,500KG and lift height from 1,600 to 3,600mm, it meets customers' demands for increasing economic performance, handling efficiency and safety.

High maneuverable, economical and practical design, it can fully meets customers' demands. With compact design, its turning radius is smaller than conventional stackers, which is more suitable for small stacking warehouse operation.



 Long-tiller Design	 Capacity 1,500kg	 Easy Maintenance	 CURTIS Technology
 Powerful Battery	 Robust Design	 High Maneuverability	 Best Cost-Performance Ratio

Highlights Presentation

General Design



- Electrical box cover is based on long-tiller series design.
- Mast is based on the existing structure design.
- Tiller is based on compact structure design.



Long-tiller design meets the requirements of ergonomics and safety

- Long-tiller design ensure the operators high efficiency and safe distance from stacker-body.
- Long-tiller stacker uses less operating force, comparedwith the short-tiller stacker.
- Height is adjustable according to operators operating habits and height preference.
- 4-wheel design with sideways long-tiller gives operators a better view to the pallet.
- The safety distance and good view makes stacking operation more efficiency and faster.



Economic but durable tiller with internal structure design and plastic coating, ensures reliable and comfortable operation. CAN-bus technology reduces the connection number and improves system reliability. CAN-bus technology is convenient to check and shoot trouble, it also reduces maintenance time. Components use digital signals has longer lifetime than those use analog signals.

CAN communication is used for all functions of the electrical system to improve the stability and consistency of performance. Handheld programmer or computer software can make diagnosis, including troubleshooting, which makes maintenance easier than other controllers used by logistics industry.

Battery deep discharge protection device, voltage discharge indicator with low voltage automatic cutting and lifting function, for higher battery lifetime. Proofed emergency switch and voltage discharge indicator, make it more durable and reliable. Indicator shows faults through CAN-bus, there is no need to remove the indicator housings.



All parts of the stacker are maintenance-convenient, no need for special tools. Built-in 8A charger. Maintenance-free Lead-acid battery, 48Vx60Ah. 48V 2.2kw powerful pump system & powerful drive.

Electric Stacker



48V DC brushless motor, low energy cost, no carbon brush, no spark, smooth operation, high efficiency, low fault rate, low maintenance cost, low noise, long lifetime.



Convenient stability casters adjustment, no need for lifting the stacker.



Stability Test Record

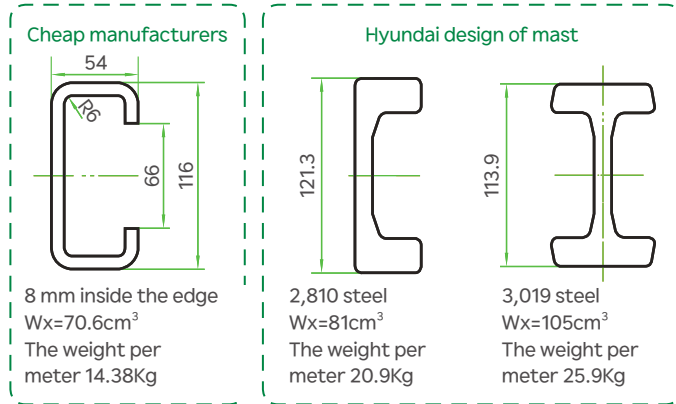

Solid steel channel for better stability and longer lifetime. High stability, safety standards (GB/T10827.1: ISO1691.1), big load value at maximum lifting height.

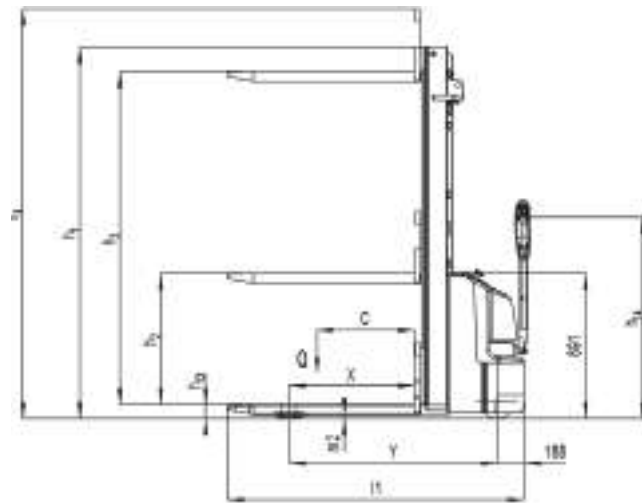
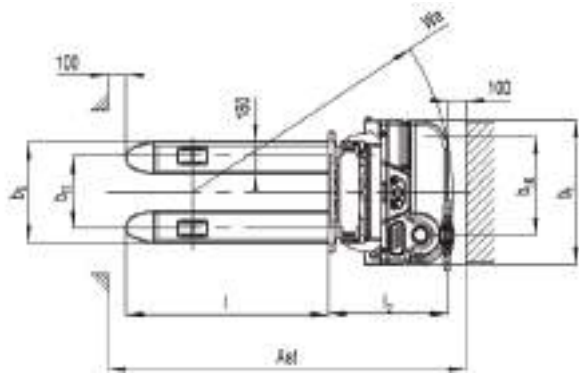

Mast table 15ES-XB/XN

Designation	Lowered mast height h1 (mm)	Free lift height h2 (mm)	Lift height h3 (mm)	Extended mast height h4 (mm)	Lift+fork height h3+h13 (mm)
One stage mast	1,978	1,510	1,515	1,985	1,600
	2,378	1,910	1,915	2,385	2,000
Two-stage mast	1,930	78	2,815	3,305	2,900
	2,080	78	3,115	3,605	3,200
	2,280	78	3,515	4,005	3,600

Type sheet for industrial truck acc. to VDI 2198

Identification		15ES-XB	15ES-XN
1.2	Manufacturer's type designation	15ES-XB	15ES-XN
1.3	Drive		Battery
1.4	Operator type		Pedestrian
1.5	Load capacity / rated load	Q (t)	1.5
1.6	Load centre distance	c (mm)	600
1.8	Load distance, centre of drive axle to fork	x (mm)	770
1.9	Wheelbase	y (mm)	1,283
Weights			
2.1	Service weight	kg	782
2.2	Axle loading, laden front / rear	kg	722 / 1,560
2.3	Axle loading, unladen front / rear	kg	544 / 238
507 / 223			
Wheels, Chassis			
3.1	Tires		Polyurethane
3.2	Tire size, front	Øx w (mm)	Ø 210×70
3.3	Tire size, rear	Øx w (mm)	Ø 80×70
3.4	Additional wheels (dimensions)	Øx w (mm)	Ø 100×50
3.5	Wheels, number front/rear (x=driven wheels)		1x +1/4
3.6	Tread, front	b10 (mm)	557
3.7	Tread, rear	b11 (mm)	410 / 525
Basic Dimensions			
4.2	Lowered mast height	h1(mm)	2,280
4.3	Free Lift height	h2(mm)	78
4.4	Lift	h3(mm)	3,615
4.5	Extended maximal height	h4(mm)	4,005
4.9	Height of tiller in drive position min. / max.	h14 (mm)	710 / 1,245
4.15	Height, lowered	h13 (mm)	85
4.19	Overall length	l1 (mm)	1,830
4.20	Length to face of forks	l2 (mm)	681
4.21	Overall width	b1 (mm)	820
4.22	Fork dimensions	s/e/l (mm)	60 / 180 / 1,150
4.25	Width across forks	b5 (mm)	570 / 685
4.32	Ground clearance, centre of wheelbase	m2 (mm)	25
4.33	Aisle width for pallets 1,000×1,200 crossways	Ast (mm)	2,317
4.34	Aisle width for pallets 800×1,200 lengthways	Ast (mm)	2,261
4.35	Turning radius	Wa (mm)	1,474
Performance Data			
5.1	Travel speed, laden / unladen	km/h	4.4 / 4.7
5.2	Lift speed, laden / unladen	m/s	0.09 / 0.14
5.3	Lowering speed, laden / unladen	m/s	0.13 / 0.126
5.8	Max. gradeability, laden / unladen	%	5 / 10
5.10	Service brake		Electromagnetic
E-Motor			
6.1	Drive motor rating S2 60min	kW	0.75
6.2	Lift motor rating at S3 10%	kW	2.2
6.3	Battery acc. to DIN 43531 / 35 / 36 A, B, C, no		N/A
6.4	Battery voltage, nominal capacity K5	V / Ah	48 / 60
6.5	Battery weight	kg	4×20
6.6	Energy consumption acc. to VDI cycle	kWh/h	0.5
0.74			
Other Details			
8.1	Type of drive control		DC
8.4	Sound level at driver's ear acc. to EN 12053	dB(A)	<70

12/16/20ES-X

Electric pedestrian stacker with capacities of 1,200/1,600/2,000kg.

INTRODUCTION

The 12/16/20ES-X series is tailored towards pedestrian controlled stacking operations with capacities from 1,200kg up to 2,000kg.

With the mounted long tiller the operator can keep a safe and ergonomic distance while performing his work.

Due to the gentle full proportional lift system, stacking operations becomes safer and faster.

With high quality and state of the art top brand components and technology, the truck competes with other leading brands in the market.

16ES-X



- Safe, compact and ergonomic long tiller design.
- Precise lifting and lowering with fully proportional Hydraulic System.
- Powerful, maintenance free German AC power train.
- Core components from top quality brands.
- 4 Wheel structure for stability.



Electric proportional lifting and lowering

The electronically controlled proportional lifting system ensures accurate positioning and stacking operations at every lifting height. In specific with high masts the electronic controlled proportional lifting performs at its best.

CAN-bus

CAN-bus technology

The CAN-bus technology is due to less wiring with more reliability. For maintenance the CAN-bus technology make analyzed and adjustments easier so that the downtime is lower than for trucks without CAN-bus. Digital signals further makes parts longer lasting than analogue signals.



Long tiller design for ergonomics and safety

With the long tiller design the operator can always keep a safe distance from the truck while working ergonomically.

This design requires less operational forces than trucks with a short tiller. The tiller's operating height is naturally installed to be Curtis ergonomic, giving the operator friendly control positions. Stacking operations become quicker and more ergonomic due to safe distancing and a better view of the forks.

The 4 wheel design with the sideways mounted long tiller gives an exact and perfect view to the forks.

Top brand qualified components

Using high quality core components :

- Reliable multifunctional REMA tiller with ergonomic contactless rocker switches.
- Top quality schabmueller AC drive motor.
- KORDEL gearbox.
- HPI hydraulic power pack.
- Curtis controller.
- Intorque brake.
- Wicke drive wheel.

The parts used reduces high service costs and comes with the performance and reliability which is required for demanding stacking operations.



Robust and reliable design

The robust chassis with strong 8mm thick apron protects the truck and the components against mechanical impacts from the environment.

In combination with the metal battery cover, the truck is well equipped to reduce maintenance work and damages to a minimum.

Dirty floor environments have less influence on the vertical AC motor design as the components and the brakes are out of reach to direct impacts.

IP 54 protected controller, safe against dust and water splashes.



German AC drive technology

The powerful maintenance free German Schabmueller AC Drive motor with German KORDEL gearbox, Intorqe brake and Wicke drive wheel all together gives the best performance, efficiency and reliability, this top brand combination reduces the overall operating cost!

Whether smooth or sudden acceleration is required, the AC Drive always give the right and direct response.



Maintenance friendly

The trucks' design and the components used are tailored to make service and maintenance easy.

All components are easy to reach after removing the main cover with only two screws.

The drive wheel and the castor wheel are easy to exchange without craning the truck.



For every application the right battery capacity

With the 12/20ES-X series every truck comes with the right battery.

- 12ES-X with 180 Ah 2VBS battery for light duty models, good maneuverability for restricted areas.
- 16ES-X with 270 Ah 3VBS battery.
- 20ES-X with 350 AH DIN 3PzS battery for long operations and multi- shifts.

Optionals

- Various mast versions
- Load backrest
- Sideway battery exchange for 16ES-X and 20ES-X

20ES-X



Mast table 12ES-X/16ES-X/20ES-X

Designation	Lowered mast height h1 (mm)	Free lift height h2 (mm)	Lift height h3 (mm)	Extended mast height h4 (mm)	Lift+fork height h3+h13(mm)
12ES-X					
Two-stage mast	1,958	/	2,810	3,380	2,900
	2,108	/	3,110	3,680	3,200
	2,308	/	3,510	4,080	3,600
Two-stage mast FFL (Full-Free-Lift)	1,958	1,410	2,810	3,380	2,900
	2,108	1,560	3,110	3,680	3,200
	2,308	1,760	3,510	4,080	3,600
Three stage mast FFL (Full-Free-Lift)	2,008	1,420	4,210	4,780	4,300
	2,108	1,520	4,510	5,080	4,600
16ES-X					
Two stage mast	1,958	/	2,810	3,380	2,900
	2,108	/	3,110	3,680	3,200
	2,308	/	3,510	4,080	3,600
Two stage mast FFL (Full-Free-Lift)	1,958	1,410	2,810	3,380	2,900
	2,108	1,560	3,110	3,680	3,200
	2,308	1,760	3,510	4,080	3,600
Three stage mast FFL (Full-Free-Lift)	1,708	1,120	3,310	3,880	3,400
	1,908	1,320	3,910	4,480	4,000
	2,008	1,420	4,210	4,780	4,300
	2,108	1,520	4,510	5,080	4,600
	2,343	1,756	5,210	5,780	5,300
2,408	1,820	5,410	5,980	5,500	
20ES-X					
Two stage mast	2,078	/	2,810	3,500	2,900
	2,228	/	3,110	3,800	3,200
	2,428	/	3,510	4,200	3,600
Two stage mast FFL (Full-Free-Lift)	1,978	1,310	2,610	3,300	2,700
	2,078	1,410	2,810	3,500	2,900
	2,228	1,560	3,110	3,800	3,200
	2,428	1,760	3,510	4,200	3,600
Three stage mast FFL (Full-Free-Lift)	1,978	1,310	3,910	4,600	4,000
	2,128	1,420	4,210	4,900	4,300
	2,228	1,520	4,510	5,200	4,600

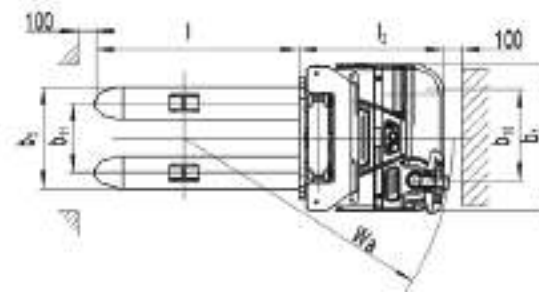
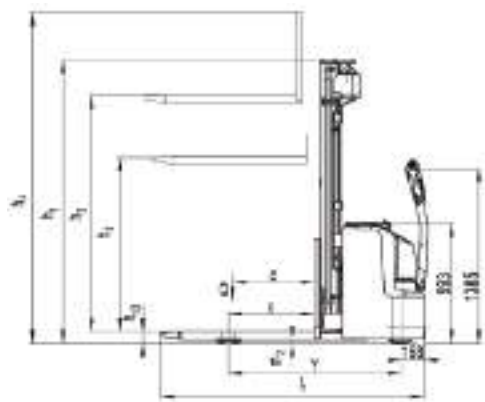

Type sheet for industrial truck acc. to VDI 2198

Identification			12ES-X	16ES-X	20ES-X
1.2	Manufacturer's type designation		12ES-X	16ES-X	20ES-X
1.3	Drive			Battery	
1.4	Operator type			Pedestrian	
1.5	Load capacity / rated load	Q (t)	1.2	1.6	2.0
1.6	Load centre distance	c (mm)		600	
1.8	Load distance, centre of drive axle to fork	x (mm)	637		647
1.9	Wheelbase	y (mm)	1,248	1,293	1,429
Weights					
2.1	Service weight	kg	1,150	1,340	1,579
2.2	Axle load at full load, drive side / load side	kg	735 / 1,610	930 / 2,010	1,000 / 2,579
2.3	Axle load at no load, drive side / load side	kg	720 / 430	850 / 490	900 / 679
Wheels, Chassis					
3.1	Tires			Polyurethane (PU)	
3.2	Tire size, front	Øx w (mm)		Ø 230 × 70	
3.3	Tire size, rear	Øx w (mm)		Ø 84 × 70	
3.4	Additional wheels (dimensions)	Øx w (mm)		Ø 150 × 54	
3.5	Wheels, number front / rear (x=driven wheels)			1x +1/4	
3.6	Tread, front	b10 (mm)		522	
3.7	Tread, rear	b11 (mm)		390 / 505	
Basic Dimensions					
4.2	Lowered mast height	h1 (mm)	2,108	2,108	2,228
4.3	Free Lift height	h2 (mm)	1,520	1,520	1,520
4.4	Lift	h3 (mm)	4,530	4,530	4,530
4.5	Extended maximal height	h4 (mm)	5,088	5,088	5,208
4.9	Height of tiller in drive position min. / max.	h14 (mm)		850 / 1,385	
4.15	Height, lowered	h13 (mm)		90	
4.19	Overall length	l1 (mm)	1,929	1,964	2,100
4.20	Length to face of forks	l2 (mm)	779	814	950
4.21	Overall width	b1 (mm)		820	
4.22	Fork dimensions	s/e/l (mm)		60 / 180 / 1,150	
4.25	Width across forks	b5 (mm)		570 / 685	
4.32	Ground clearance, centre of wheelbase	m2 (mm)	28	28	23
4.33	Aisle width for pallets 1,000 × 1,200 crossways	Ast (mm)	2,336	2,406	2,536
4.34	Aisle width for pallets 800 × 1,200 lengthways	Ast (mm)	2,323	2,393	2,523
4.35	Turning radius	Wa (mm)	1,400	1,510	1,640
Performance Data					
5.1	Travel speed, laden / unladen	km/h	6.0/6.0	5.7/6.0	5.4/6.0
5.2	Lift speed, laden / unladen	m/s		0.11 / 0.23	
5.3	Lowering speed, laden / unladen	m/s		0.21 / 0.225	
5.8	Max. gradeability, laden / unladen	%	6 / 12	6 / 12	6 / 10
5.10	Service brake			Electromagnetic	
E-Motor					
6.1	Drive motor rating S2 60min	kW	1.3	1.3	1.7
6.2	Lift motor rating at S3 10%	kW	3.2	3.2	3.2
6.3	Battery acc. to DIN 43531/ 35/ 36 A, B, C, no		2VBS	3VBS	3PZS
6.4	Battery voltage, nominal capacity K5	V / Ah	24 / 180	24 / 270	24 / 350
6.5	Battery weight	kg	175	230	288
6.6	Energy consumption acc. to VDI cycle	kWh/h	0.95	1.59	1.70
Other Details					
8.1	Type of drive control			AC-Speed control	
8.4	Sound level at driver's ear acc. to EN 12053	dB(A)		<70	

16/20ESR-X

Electric pallet stacker

Suspension system

5-wheel structural design

More adaptable to complex ground

Equipped with driving wheel floating technology, 16/20ESR-X is more adaptable to complex ground and not easy to slip. The fixed balance wheel on both side enhances the stability and passability of the truck.

Driving wheel with pressure adjustable structure, is more practical for different application scenarios and vehicle weights.

Driving wheel floating technology, combined with foldable platform floating structure, makes the truck higher effective in shock absorption and more comfortable in operation.



High-performance Lithium battery



Robust Design



High-pass sex



Cost-effective



Capacity 1,600/2,000kg



Easy Maintenance



Low noise



LiFePO4 battery

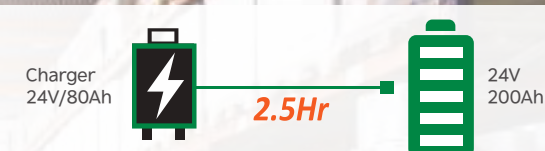

Charger 24V/80Ah **2.5Hr** 24V 200Ah

All Li-ion batteries are equipped with on-board Battery Management System (BMS), which provides mandatory control of all important parameters of the battery during charging and operation. With this control, the safety of Li-ion battery during the whole life-cycle is guaranteed. The Li-ion batteries are certified according to international safety transportation (by sea and by air) and operation standards. The BMS communicates with control system of the truck via CAN, the support of the CAN protocols allows to monitor the condition of the battery and make its diagnosis with help of special software which is available for our partners.



High efficiency of the truck can be guaranteed under the condition of multi-shift operations. Lithium battery can be selected. Lithium battery features in fast charging, maintenance-free, environmental protection and intelligent display functions. Besides, the cost is very low from the perspective of long-term ownership and maintenance, and work efficiency is improved.

The multi-function and flexible 16/20ESR-X Series is the ideal choice for stacking operations.

Core parts



German REMA handle with reliable and ergonomic control system. Additionally, the non-contact lifting and lowering rocker switch extends the life of the handle.



The Curtis controller provides customers with reliable and flexible high performance control system solutions.



Integrated functional area, equipped with key switch, emergency switch, battery indicator and USB charging port.

Optional electric power steering system adopted in short-tiller stackers can control the steering wheel quickly and accurately, meeting the standards with high reliability and safety.

The robust chassis with 8mm thick apron protects the truck and the components against battery cover ensures the battery well protected.



Optional parts



Optional Pin Panel Access, ensuring to manually input password or to swipe to start by RFID cards.

Optional built-in charger, simplifying battery charging work.



Optional French HPI hydraulic system for proportional lift helps to ensure accurate positioning of the fork during lifting and lowering. The acceleration and deceleration of the fork are smoother, so fragile items can be operated.



Optional side battery extraction, through a special trailer, high effective in battery replacement, and convenient for multi-shift operation.

Mast table 16/20ESR-X

Designation	Height, mast lowered h1 (mm)	Free lift h2 (mm)	Lift h3 (mm)	Height, mast extended h4 (mm)	Lift+fork height h3+h13 (mm)
16ESR-X					
Two stage mast	1,958	-	2,810	3,380	2,900
	2,108	-	3,110	3,680	3,200
	2,308	-	3,510	4,080	3,600
Two stage mast FFL (Full-Free-Lift)	1,958	1,410	2,810	3,380	2,900
	2,108	1,560	3,110	3,680	3,200
	2,308	1,760	3,510	4,080	3,600
Three stage mast FFL (Full-Free-Lift)	1,708	1,120	3,310	3,880	3,400
	1,908	1,320	3,910	4,480	4,000
	2,008	1,420	4,210	4,780	4,300
	2,108	1,520	4,510	5,080	4,600
	2,343	1,576	5,210	5,780	5,300
	2,410	1,820	5,410	5,980	5,500
20ESR-X					
Two stage mast	2,078	-	2,810	3,500	2,900
	2,228	-	3,110	3,800	3,200
	2,428	-	3,510	4,200	3,600
Two stage mast FFL (Full-Free-Lift)	1,978	1,310	2,610	3,300	2,700
	2,078	1,410	2,810	3,500	2,900
	2,228	1,560	3,110	3,800	3,200
Three stage mast FFL (Full-Free-Lift)	1,978	1,310	3,910	4,600	4,000
	2,128	1,420	4,210	4,900	4,300
	2,228	1,520	4,510	5,200	4,600

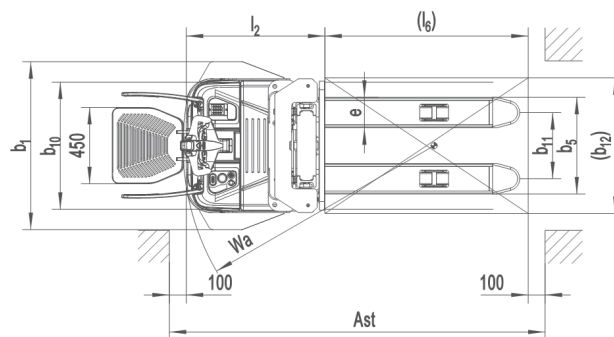
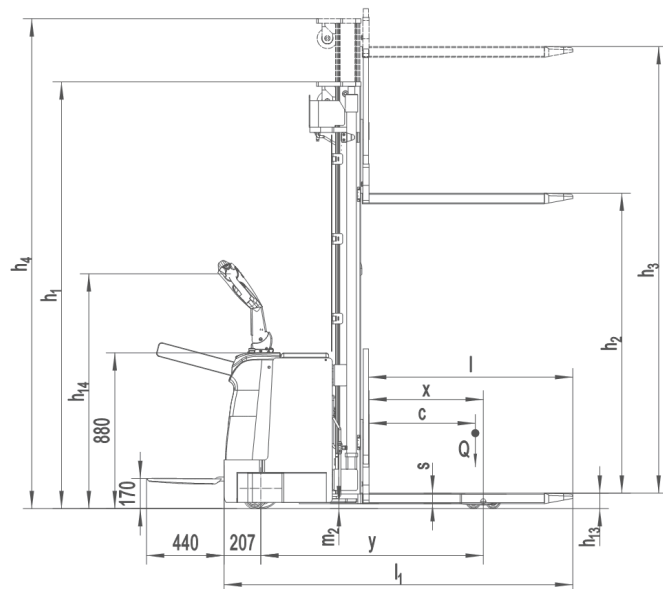

Type sheet for industrial truck acc. to VDI 2198

Identification		16ESR-X	20ESR-X	
1.2	Manufacturer's type designation	16ESR-X	20ESR-X	
1.3	Drive	Battery		
1.4	Operator type	Pedestrian		
1.5	Load capacity / rated load	Q (t)	1.6	2.0
1.6	Load centre distance	c (mm)	600	
1.8	Load distance, centre of drive axle to fork	x (mm)	647	650
1.9	Wheelbase	y (mm)	1,256	1,392
Weights				
2.1	Service weight	kg	1,365	1,630
2.2	Axle load at full load, drive side / load side	kg	1,000 / 1,965	1,124 / 2,506
2.3	Axle load at no load, drive side / load side	kg	943 / 422	1,067 / 563
Wheels, Chassis				
3.1	Tires	Polyurethane (PU)		
3.2	Tire size, front	Øx w (mm)	Ø 230×70	
3.3	Tire size, rear	Øx w (mm)	Ø 84×70	
3.4	Additional wheels (dimensions)	Øx w (mm)	Ø 124×60	
3.5	Wheels, number front / rear (x=driven wheels)		1x+2/4	
3.6	Tread, front	b10 (mm)	750	
3.7	Tread, rear	b11 (mm)	390 / 505	
Basic Dimensions				
4.2	Lowered mast height	h1 (mm)	2,410	2,228
4.3	Free Lift height	h2 (mm)	1,820	1,520
4.4	Lift	h3 (mm)	5,430	4,530
4.5	Extended maximal height	h4 (mm)	6,110	5,200
4.9	Height of tiller in drive position min. / max.	h14 (mm)	950 / 1,350	
4.15	Height, lowered	h13 (mm)	90	
4.19	Overall length	l1 (mm)	1,968 ¹⁾	2,101 ¹⁾
4.20	Length to face of forks	l2 (mm)	818 ¹⁾	951 ¹⁾
4.21	Overall width	b1 (mm)	990	
4.22	Fork dimensions	s/e/l (mm)	60 / 180 / 1,150	
4.25	Width across forks	b5 (mm)	570 / 685	
4.32	Ground clearance, centre of wheelbase	m2 (mm)	28	
4.33	Aisle width for pallets 1,000X1,200 crossways	Ast (mm)	2,396 ¹⁾	2,530 ¹⁾
4.34	Aisle width for pallets 800X1,200 lengthways	Ast (mm)	2,382 ¹⁾	2,516 ¹⁾
4.35	Turning radius	Wa (mm)	1,500 ¹⁾	1,634 ¹⁾
Performance Data				
5.1	Travel speed, laden / unladen	km/h	7.0 / 8.0	
5.2	Lift speed, laden / unladen	m/s	0.125 / 0.23	
5.3	Lowering speed, laden / unladen	m/s	0.26 / 0.225	
5.8	Max. gradeability, laden / unladen	%	6 / 12	
5.10	Service brake		Electromagnetic	
E-Motor				
6.1	Drive motor rating S2 60min	kW	1.4	
6.2	Lift motor rating at S3 10%	kW	3.0	
6.3	Battery acc. to DIN 43531/ 35/ 36 A, B, C, no		3VBS	3PZS
6.4	Battery voltage, nominal capacity K5	V / Ah	24 / 270	24 / 350
6.5	Battery weight	kg	230	288
6.6	Energy consumption acc. to VDI cycle	kWh/h	1.34	1.70
Other Details				
8.1	Type of drive control		AC-Speed control	
8.4	Sound level at driver's ear acc. to EN 12053	dB(A)	<70	

1) With compact platform: +440mm

30/50ET-X

Stand-on tow tractor

Rated capacity: 3,000kg/5,000kg

INTRODUCTION

30/50ET-X is a stand-on tow tractor equipped with German three-phase AC drive motor and Curtis controller which ensures strong power and smooth acceleration and deceleration. Electric Power Steering(EPS) and German REMA handle ensures high efficiency and provides excellent driving experience.

4-point structure with floating platform and rubber pad helps to minimize vibration. Automotive grade curved backrest can reduce worker's fatigue greatly. Side extraction allows for fast replacement of battery so as to fulfill the needs of multi shifts.

Other options available include extension bracket, warning light, blue spot light, electric coupling, big storage tray, double USB charging ports, storage tray etc. which helps to make your work easier and more efficient.



Display whole truck condition information via control instrument and multifunctional handle



The multi-functional control instrument can display truck conditions, battery capacity, working time, travel speed and steering angle. When something goes wrong, the outer ring light of the instrument will turn to red from green, and the fault code will be displayed.

Pin code switch can set multiply start passwords, the ID card is also supported to start the truck.



USB charging port

Double USB charging port power up more equipment.



German REMA multifunctional handle

Reliable and ergonomically designed Rema handle, each button can be easily reached and controlled, which makes driving more comfortable.

Robust and durable structure, high power and efficient driving technology

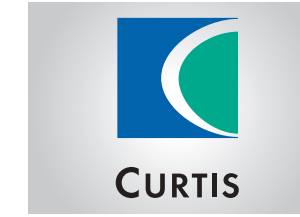

The Curtis controller provides customers with reliable and flexible high performance control system solutions.



German AC drive technology

AC drive system performs perfectly thanks to the powerful Schabmueller maintenance free AC motor and KORDEL gearbox imported from Germany, regardless of smooth or fast acceleration.



German drive wheel tyre delivers much longer service life with high loading capacity and extraordinary abrasive resistance.

50ET-X



50ET-X

- Rated capacity: 5t
- Rated pulling capacity: 1,000N
- Travel speed(laden/unladen): 7/12 km/h
- Drive unit: 2.6kW
- Standard 24V465Ah Lead-acid battery
- Wheels' number 1x+2/2(x=driven wheels)

30ET-X

- Rated capacity: 3t
- Rated pulling capacity: 800N
- Travel speed(laden/unladen): 6/9km/h
- Drive unit: 1.9kW
- Standard 24V375Ah Lead-acid battery
- Wheels' number 1x+2(x=driven wheels)

Safe and comfortable, large storage tray



The standard blue light is not only automatically activated when the truck is driving forward, but also turns simultaneously with the handle while steering, which will increase the safety of operation.



Warning light makes driving safer.



Steering light, brake light and parking light make driving safer.



Safety flanks and non-slip surface materials on both sides of the backrest ensure the operator not to be thrown off while the truck turns at high speed. This design greatly improves the safety of driving. Meanwhile, the handle above the backrest provides a grasping point for the operator while getting on/off the truck, provides superior comfort for the operator.



Large storage tray can be used for storing stretch film, art knife, marker pen, or other tools.



Double storage tray can separate storage tools or garbage, makes work more efficient.

Other optional parts



A variety of expansion brackets can be selected to meet the installation requirements of different expansion equipment, such as: WMS display, barcode scanner, storage box, folder board, etc.



The reinforced couplers can be set at three different heights so as to ensure the reliable connection to various trailers.

Well-designed and easy to maintain



Suspension castors from both sides make the vehicle run more smoothly and safely.



The coasting button on both sides of the truck and emergency stop button allow the operator to operate truck forward/backward while walking beside. There is no need to get in and out of the truck frequently to operate it. At the same time, it reduces the speed while driving forward/backwards under coasting mode, making the traction safer and more efficient.



Sideways battery exchange compartment plus adjustable handling bracket makes battery replacement easier and quicker.



30ET-X

Type sheet for industrial truck acc. to VDI 2198

Identification		30ET-X	50ET-X	
1.2	Manufacturer's type designation	30ET-X	50ET-X	
1.3	Drive	Battery		
1.4	Operator type	Stand-on		
1.5	Load Capacity / rated load	Q (t)	3.0	5.0
1.8	Rated drawbar pull	F (N)	800	1,000
1.9	Wheelbase	y (mm)	1,155	
Weights				
2.1	Service weight	kg	950	1,020
2.3	Axle load at no load, drive side / load side	kg	550 / 400	610 / 410
Wheels, Chassis				
3.1	Tires		Solid rubber	
3.2	Tire size, front	Øx w (mm)	Ø 230×70	Ø 250×80
3.3	Tire size, rear	Øx w (mm)	Ø 180×76	
3.4	Additional wheels (dimensions)	Øx w (mm)	Ø 124×60	
3.5	Wheels, number front / rear (x=driven wheels)		1x / 2	1x+2 / 2
3.6	Tread, front	b10 (mm)	580	
3.7	Tread, rear	b11 (mm)	614	
Basic Dimensions				
4.9	Height of tiller in drive position min./ max.	h14 (mm)	1,280	
4.12	Coupling height (hook center above ground)	h10 (mm)	230 / 330 / 430	
4.19	Overall length	l1 (mm)	1,429 ¹⁾	
4.21	Overall width	b1 (mm)	810	
4.32	Ground clearance, centre of wheelbase	m2 (mm)	50	
4.35	Turning radius	Wa (mm)	1,333 ²⁾	
Performance Data				
5.1	Travel speed, laden / unladen	km/h	6 / 9	7 / 12
5.5	Drawbar pull, laden / unladen	N	800	1,000
5.6	Max. drawbar pull, laden / unladen	N	2,000	3,000
5.10	Service brake		Electromagnetic	
E-Motor				
6.1	Drive motor rating S2 60min	kW	1.9	2.6
6.3	Battery acc. to DIN 43531 / 35 / 36 A, B, C, no		No	
6.4	Battery voltage, nominal capacity K5	V / Ah	24 / 375	24 / 465
6.5	Battery weight	kg	292	352
Other Details				
8.1	Type of drive control		AC-Speed control	
8.4	Sound level at driver's ear acc. to EN 12053	dB (A)	<70	

1) Install crash pads l1=1,469mm 2) Install crash pads Wa=1,359mm

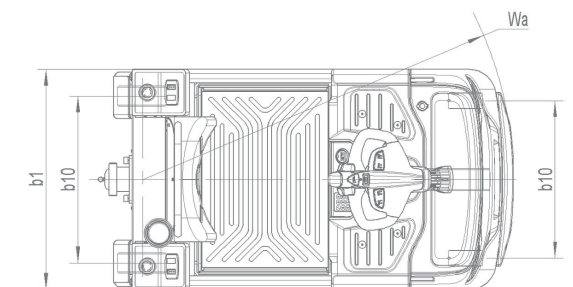
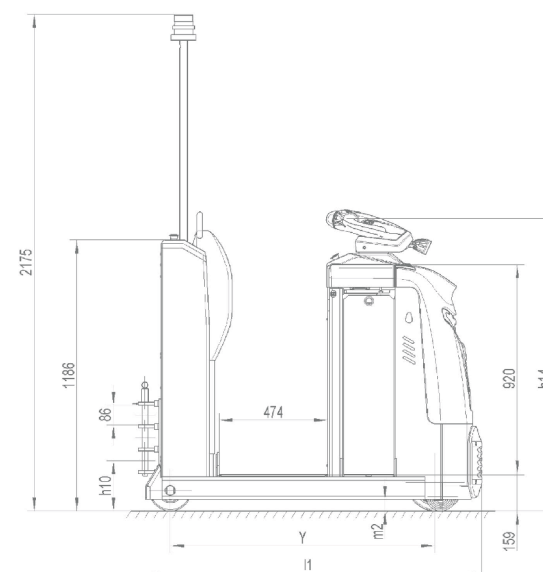

25EO-X

Low-level order picker

25EO-X is a low-level order picker that has strong power and better stability when increasing or decreasing speed thanks to the German AC drive and Curtis controller. Plus its electric steering system and German REMA multi-functional handle make it has high working efficiency and driving comfort.

4 point structure floating shock absorption platform and rubber pads minimize the vibration. The ergonomically curved backrest can efficiently avoid driver's fatigue; Sideways battery design allows quick and easy replacement in multi shifts working.

Fully upgraded features make picking easier and more efficient and it provides various optional configurations such as extension bracket, caution light, blue light, entry rollers, storage tray, double USB charging port, etc.

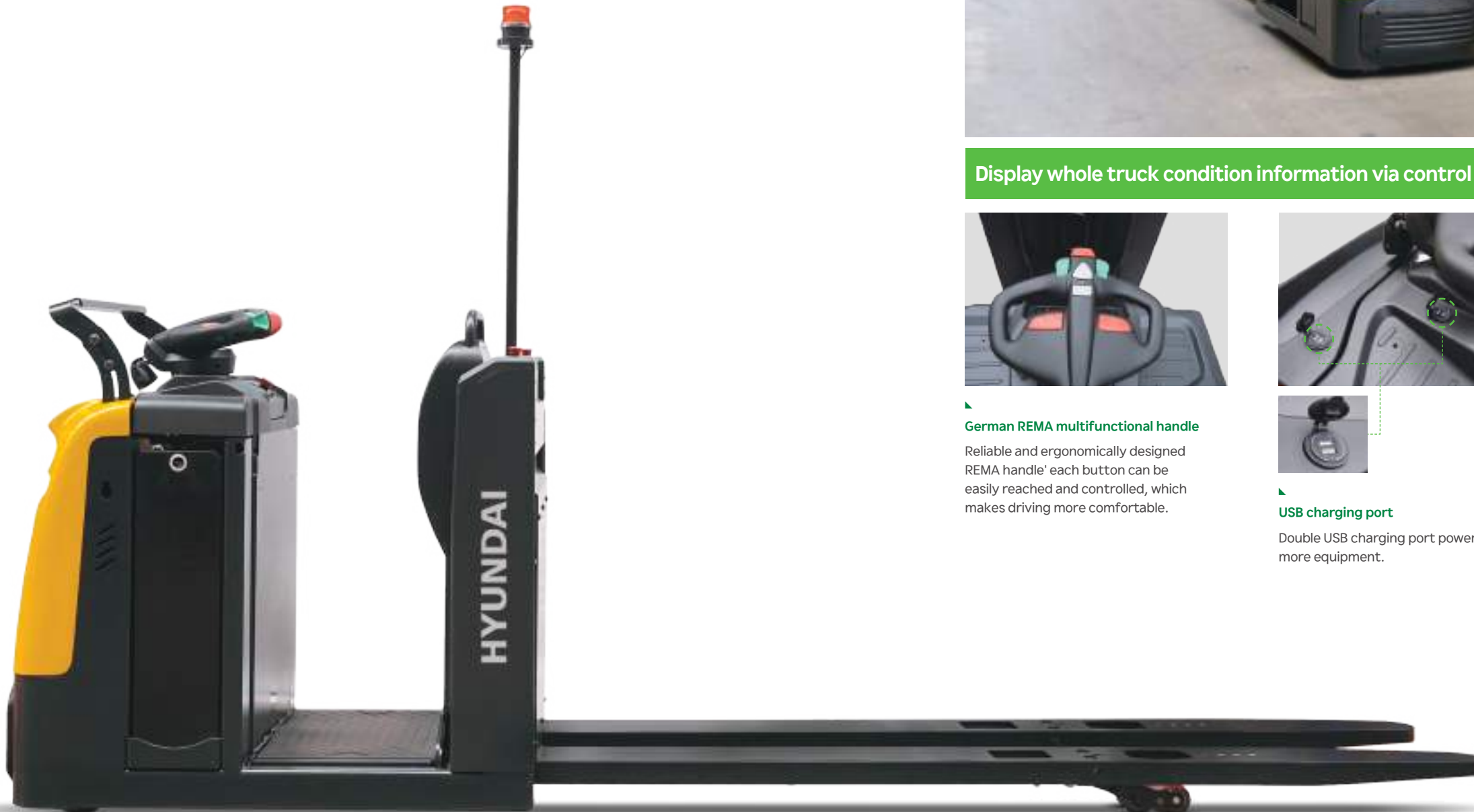

Display whole truck condition information via control instrument and multifunctional handle



German REMA multifunctional handle

Reliable and ergonomically designed REMA handle' each button can be easily reached and controlled, which makes driving more comfortable.



USB charging port

Double USB charging port power up more equipment.



The multifunctional control instrument can display truck conditions, battery capacity, working time, travel speed, and steering angle. When something goes wrong, the outer ring light of the instrument will turn to red from blue.

The standard pin code switch can set multiply start passwords, the ID card is also supported to start the truck.

Robust and durable structure, high power and efficient driving technology

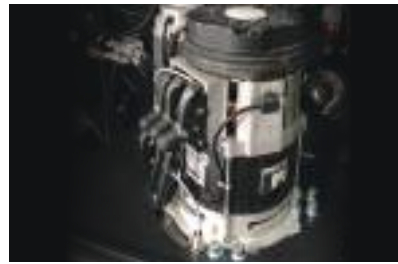

German AC drive technology

AC drive system performs perfectly thanks to its high power maintenance-free Geman Schabmuller AC drive motor and KORDEL gearbox while smoothly increasing or decreasing speed.



High power and performance pump

Make lift easier and efficient by using high power and performance pump.

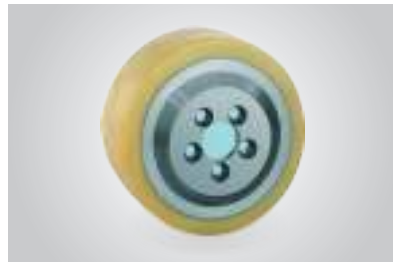

German drive wheel ring has a long service life, high load, and is not easy to wear.



German load wheel has a long service life but a lower cost.

The reinforced welded fork is more robust and durable. Adopting adjustable trolley design in lifting that makes height adjustment and maintenance easier and convenient.



Well-designed and easy to maintain

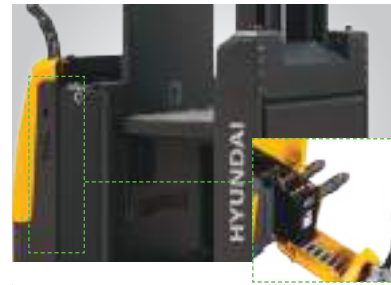

Sideways battery exchange compartment plus adjustable handling bracket makes battery replacement easier and quicker.



The upper adjustable balance wheel can realize the easy adjustment of the balance wheel.



A variety of extension supports are available to meet the installation requirements of different extension equipment, such as WMS display, barcode scanner, storage tray, file plywood, etc.

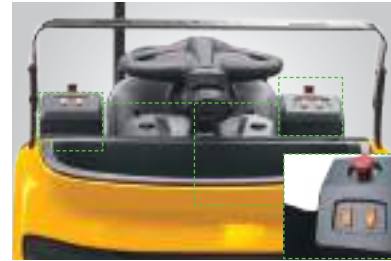

The jog button on both sides of the truck allows the operator to operate truck forward / backward or lift the fork while walking beside. There is no need for the operator to get in and out of the truck frequently to operate it. That greatly improved the picking efficiency and operation safety by reducing the speed controlled by the jog button.



Easier to entry Australian pallet with entry rollers.

Safe and comfortable, easy storage



The standard blue light does not only automatically lit while the truck forwarding but also follows the handle to turn while the truck turns. It greatly improves the safety of the operation.



Safety flanks and non-slip surface materials on both sides of the backrest ensure the operator not to be thrown off while the truck turns at high speed. This design greatly improves the safety of driving. Meanwhile, the handle above the backrest provides a grasping point for the operator when get up or down the truck, provides superior comfort for the operator.



Large storage tray can be used for storing stretch film, art knife, marker pen, or other tools.

Other optional parts



A: The storage platform used with the lifting operation platform allows putting or retrieving more cargo and make work more efficient.

B: The operation platform can be lifted to the second rack which allows picking or retrieving more efficient.

C: Operating platform descent by using foot switch releases the hands to make more work.

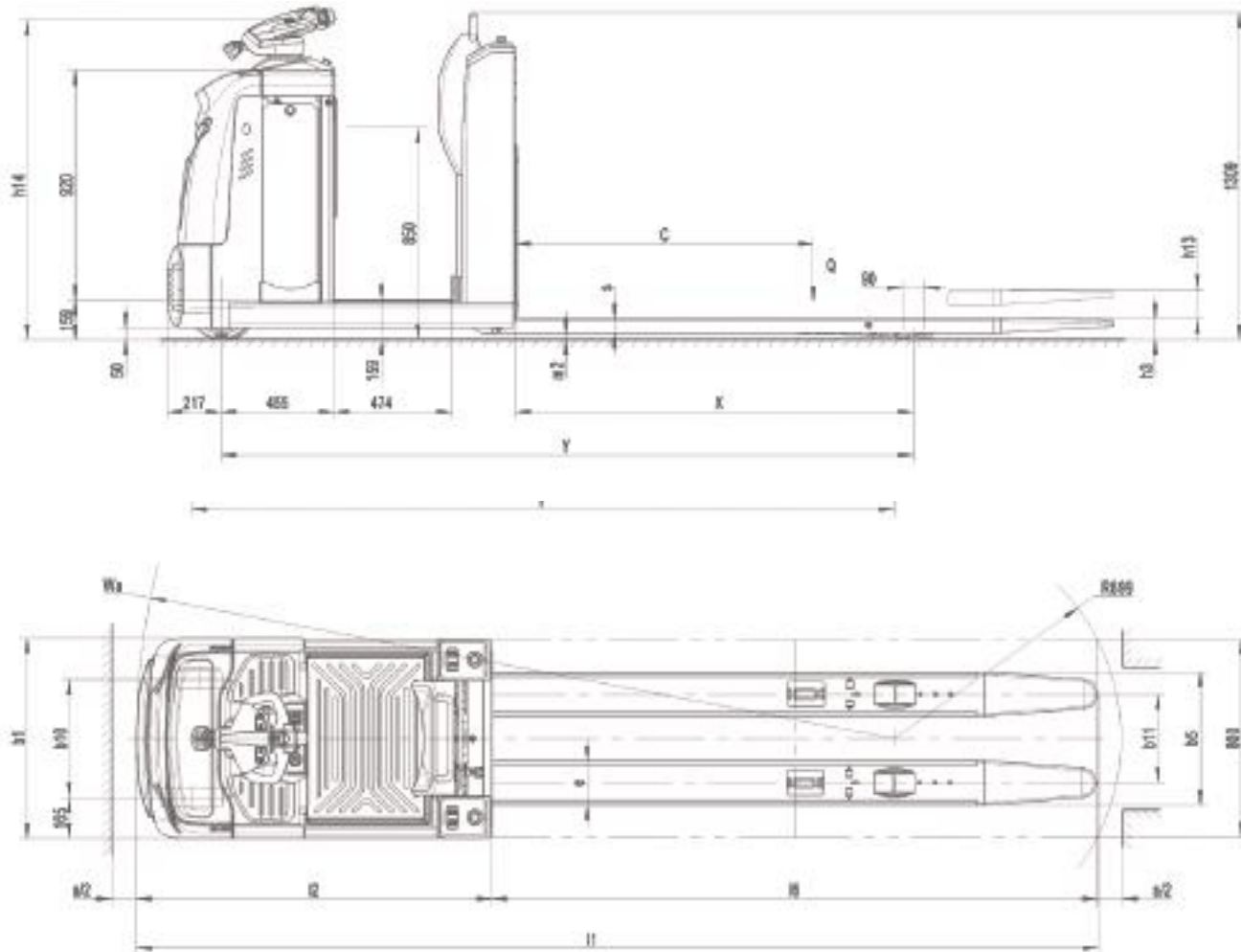

Type sheet for industrial truck acc. to VDI 2198

Identification

1.2	Manufacturer's type designation		25EO-X
1.3	Drive		Battery
1.4	Operator type		Order-picker
1.5	Load capacity / rated load	Q (t)	2.5
1.6	Load centre distance	c (mm)	1,200
1.8	Load distance, centre of drive axle to fork	x (mm)	1,535 ¹⁾
1.9	Wheelbase	y (mm)	2,723 ¹⁾

Weights

2.1	Service weight	kg	968
2.2	Axle loading, laden front / rear	kg	1,290 / 2,530
2.3	Axle loading, unladen front / rear	kg	980 / 340

Wheels, Chassis

3.1	Tires		Polyurethane(PU)
3.2	Tire size, front	Øx w (mm)	Ø 250 × 80
3.3	Tire size, rear	Øx w (mm)	Ø 82 × 82
3.4	Additional wheels (dimensions)	Øx w (mm)	Ø 180 × 80
3.5	Wheels, number front / rear (x=driven wheels)		1+1x/4
3.6	Tread, front	b10 (mm)	480
3.7	Tread, rear	b11 (mm)	360

Basic Dimensions

4.4	Lift	h3 (mm)	115
4.9	Height of tiller in drive position min. / max.	h14 (mm)	1,280
4.15	Height, lowered	h13 (mm)	85
4.19	Overall length	l1 (mm)	3,770 ²⁾
4.20	Length to face of forks	l2 (mm)	1,370 ²⁾
4.21	Overall width	b1 (mm)	810
4.22	Fork dimensions	s/e/l (mm)	60 / 180 / 2,400
4.25	Width across forks	b5 (mm)	540
4.32	Ground clearance, centre of wheelbase	m2 (mm)	25
4.34	Aisle width for pallets 800 × 1,200 lengthways	Ast (mm)	3,970 ³⁾⁴⁾
4.35	Turning radius	Wa (mm)	2,965 ³⁾

Performance Data

5.1	Travel speed, laden / unladen	km/h	9 / 12
5.2	Lift speed, laden / unladen	mm/s	40 / 64
5.3	Lowering speed, laden / unladen	mm/s	60 / 40
5.8	Max. gradeability, laden / unladen	%	6 / 12
5.10	Service brake		Eletromagnetic

E-Motor

6.1	Drive motor rating S2 60min	kW	2.6
6.2	Lift motor rating at S3 10%	kW	2.2
6.3	Battery acc. to DIN 435 31 / 35 / 36 A, B, C, no		No, 3PzS
6.4	Battery voltage, nominal capacity K5	V / Ah	24 / 465
6.5	Battery weight	kg	352
6.6	Energy consumption acc. to VDI cycle	kWh/h	0.7

Other Details

8.1	Type of drive control		AC-Speed control
8.4	Sound level at driver's ear acc. to EN 12053	dB(A)	<70

1) After the fork descent x=1,600mm, y=2,788mm

2) Install crash pads l1=3,810mm, l2=1,409

3) Install crash pads Wa=3,005mm, Ast=4,010mm

4) According to the VDI diagonal algorithm Ast=original measurement +94mm

You can visit
the HD Hyundai XiteSolution
website by scanning
the QR code



*Details may vary depending on sales market and body type.
Photos, specifications, features and equipment shown
in this publication are based upon the latest available information.
Copyright © HD Hyundai XiteSolution Company. All Rights Reserved.

<https://www.hd-xitesolution.com/>