



■ The photograph and the actual equipment may differ in appearance.

HYUNDAI MATERIAL HANDLING **Environmentally - Friendly**

25/30/33DF-7

25/30/33DF -7

New criterion of Forklift Trucks

Hyundai introduces a new line of 7series diesel forklift trucks. Excellent power and performance makes your business more profitable.



■ The photograph and the actual equipment may differ in appearance.

High Power & Performance

Powerful Engine
HMC D4BB Engine (25/30/33DF-7)
39kW/2,500rpm



Market approved quality of HMC D4BB engine ensures incomparable performance, durability and additional value to the machine, 39kW of the engine is more than enough to suit

any work, not just with normal 39kW but with special attachments requiring high power as well (Eu stage III A certified)

State-of-the-art hydraulic system

The latest large-capacity hydraulic system reacts quickly during operation, and a low-noise control valve increases both efficiency and durability.

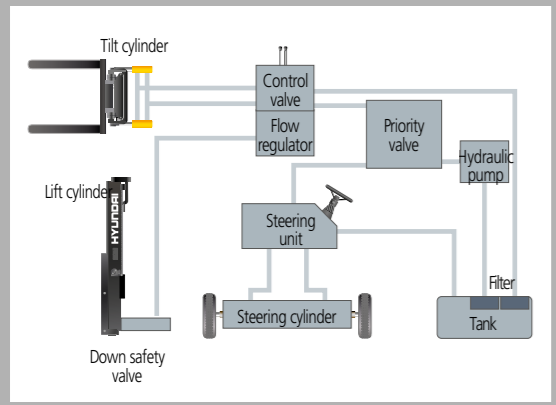

Increased mast tilting angle
 Utilizing the standard mast tilting angle of 6 degrees forward and 10 degrees backward, the operator can safely and rapidly perform loading and unloading jobs.



The new master on the job-site!

Smooth running, efficient and ergonomically designed, 25/30/33DF-7 series are made to meet your needs.

■ The photograph and the actual equipment may differ in appearance.



Fast and stable performance
 Being able to quickly raise and lower the mast, as well as tilt it forward and backward, provides the best operational conditions during unloading. When the truck is fully loaded, mast lowering speed is carefully controlled to ensure safety by the down control valve.

Faster travel speed & gradeability
 The powerful high-output engine provides greater acceleration, better gradeability and faster travel speed on any tough terrain or slope.

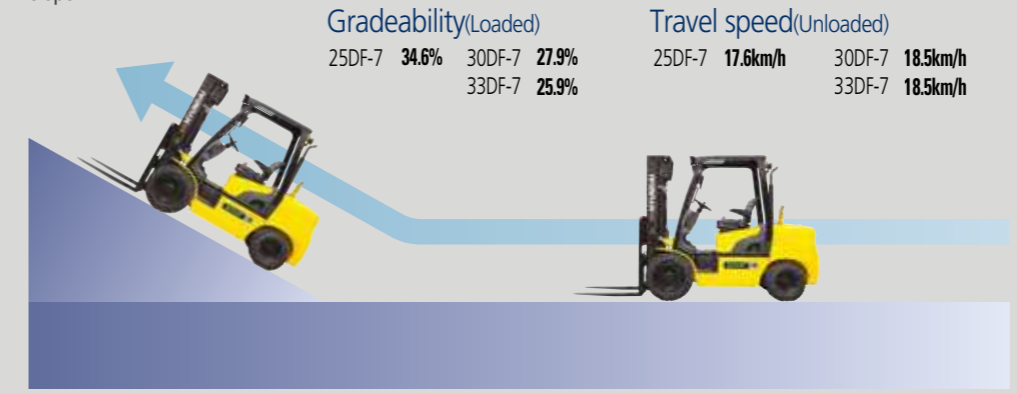

Wet disc brake system
 The wet disc brake system is virtually maintenance free and is enclosed to protect from dust and water.



Fully hydrostatic power steering
 A hydraulic steering system always guarantees smooth and flexible steering, preventing overrun and kick-back.



OPSS (Operator Presence Sensing System)
 Control of mast tilting, lifting and lowering is not possible through operation of the appropriate control when the operator is not in the normal position. **Option**

Comfortable Operation



Adjustable steering wheel

Steering wheel with horn button can be adjusted by a lever on the right-hand side for the most comfortable operator position.



Easy and safe shift lever

A single lever on the left side of the steering column gives the operator fast, easy control of direction.



Multi-function switch lever

Multi-functional switch lever gives easy access to lights and horn.



Quick response of operating control levers

Only minimal operator's effort is required for precise, safe and productive control.



■ The photograph and the actual equipment may differ in appearance.

Ergonomically designed with the operator in mind!

A design based on human engineering relieves fatigue and increase operator's efficiency.



Ergonomically positioned pedals

Based on human engineering, the accelerator, brake and inching pedals are optimally positioned for convenience while operating the equipment.



Cup holder & console box

Additional storage spaces are located inside the operating space for operator's convenience.



New high visibility for safe operation

The operator is able to work with increased safety and accuracy due to a wider view mast.

Operator friendly gauges and water-resistant monitor panel

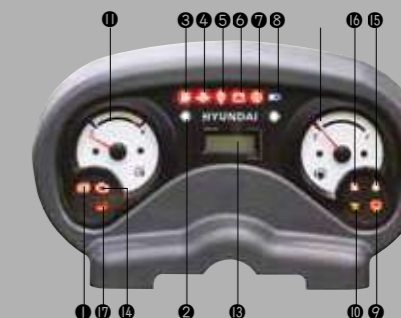

- | | |
|---|---------------------------|
| ① Parking brake lamp | ④ Water separator lamp |
| ② Directional indicators | ⑩ Pre-heater indicator |
| ③ Fuel warning lamp | ⑪ Water temperature gauge |
| ④ Engine oil warning lamp | ⑫ Fuel gauge |
| ⑤ Transmission oil temperature warning lamp | ⑬ Hour meter |
| ⑥ Battery charging warning lamp | ⑭ Engine check lamp |
| ⑦ Air cleaner filter warning light | ⑮ Seat belt warning |
| ⑧ Working light indicator | ⑯ OPSS warning(Optional) |

Grammer Seat Option

An attractive and adjustable seat, based on a human engineering design, provides great comfort. And the angle of the armrest can be adjusted to reduce the fatigue of the driver.

- Applied the weight of the driver(45~170kg)
- ELR type seat belt standard



Full floating overhead guard mount

The anti-vibration rubber is installed between the guard and truck frame to reduce the source of vibration and noise while driving. This not only reduces operator's fatigue but also increases safety.



Endurance & Safety

Strong overhead guard

The safety overhead guard exceeds EEC and ANSI regulations and protects the operator during hazardous jobs.



Parking brake

Ratchet type parking brake requires less efforts from the operator to set.



Highly durable split type drive axle

The bevel gear set and hub reduction axle smoothly delivers desired torque to the drive wheels.



Enhanced safety through high durability!

Safety and durability are priorities in the design of the equipment.

The photograph and the actual equipment may differ in appearance.



Large footboard & hand grip

Wide "open" step offers convenience and safety when entering and exiting truck.

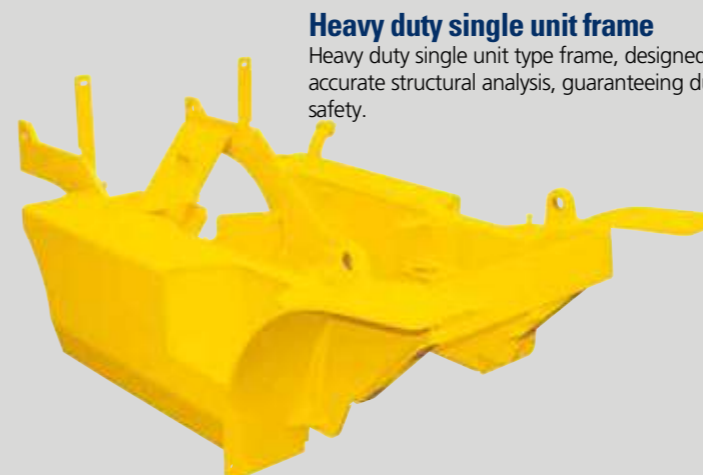

Heavy duty single unit frame

Heavy duty single unit type frame, designed on the basis of accurate structural analysis, guaranteeing durability and safety.



Easy access of electrical Components

Various electric parts are centralized in dash board resulting in improvement in maintenance



Bright, protected headlights

Bright, protected headlights is positioned for exceptional visibility.

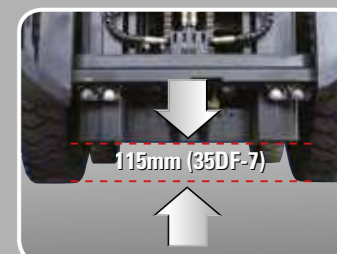

Ground clearance

The engine and transmission are assembled horizontally and positioned high in the frame to protect expansive components during operation on rugged surface.

Centralized design for **easy service!**

An ideal arrangement of component parts ensures easy access and convenience for maintenance.



The photograph and the actual equipment may differ in appearance.



Electrically monitored air filter

Air cleaner sensor alerts the operator of a restricted air filter and allows replacement before damage.



Brake fluid reservoir

Highly visible, easily accessible reservoir makes for quicker daily inspections.



An accessible, compact fuse box for easy inspection



Easy change air cleaner

The air filter is readily accessible for cleaning or replacement. (7inch Cyclone Type)



Tool-less floor plate for serviceability.



Large open engine hood

Highly accessible engine compartment assures fast and efficient maintenance.



Hydraulic oil check



Automatic self locking gas spring

Engine compartment hood is held safely open by a self locking gas spring.



Portable side cover

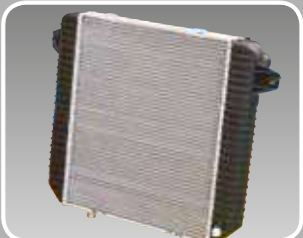

Aluminum radiator with superb protection against heat



Engine oil condition check

Specification

Mast Specification (25DF-7)

Mast Type	Maximum Fork Height		Overall Height (Lowered)		Free Lift Height						Tilt Angle		Load capacity w/o side shift				Load capacity w/side shift				TRUCK WEIGHT (UNLOAD)									
					with bkr		w/o bkr		w/o bkr (3/4-SPOOL)		Fwd	Bwd	Single Tire		Double Tire		Single Tire		Double Tire		Single Tire		Double Tire							
	in	mm	in	mm	in	mm	in	mm	in	mm	deg	deg	24 in LC	500mm LC	24 in LC	500mm LC	24 in LC	500mm LC	24 in LC	500mm LC	24 in LC	500mm LC	lb	kg	lb	kg	lb	kg	lb	kg
2-STAGE LIMITED FREE LIFT	*V300	118.1	3,000	79.7	2,025	6.1	155	6.1	155	6.1	155	6	10	5,000	2,500	5,000	2,500	5,000	2,500	5,000	2,500	8,208	3,723	8,508	3,859					
	V330	129.9	3,300	85.6	2,175							6	10	5,000	2,500	5,000	2,500	5,000	2,500	5,000	2,500	8,251	3,743	8,551	3,879					
	V350	137.8	3,500	89.6	2,275							6	10	5,000	2,500	5,000	2,500	5,000	2,500	8,288	3,760	8,589	3,896							
	V370	145.7	3,700	95.5	2,425							6	10	5,000	2,500	5,000	2,425	5,000	2,500	8,337	3,782	8,637	3,918							
	V400	157.4	4,000	101.4	2,575							6	10	5,000	2,460	5,000	2,500	5,000	2,385	5,000	2,425	8,403	3,812	8,703	3,948					
	V450	177.2	4,500	113.2	2,875							6	6	4,900	2,350	5,070	2,430	4,850	2,275	4,960	2,355	8,566	3,885	8,866	4,022					
3-STAGE FULL FREE LIFT	TF430	169.3	4,300	79.7	2,025	33.3	845	54.2	1,377	53	1,346	6	6	4,900	2,340	5,000	2,410	4,850	2,265	4,900	2,335	8,601	3,901	8,903	4,038					
	TF450	177.2	4,500	83.7	2,125	37.2	945	58.1	1,477	58	1,477	6	6	4,790	2,310	4,900	2,380	4,740	2,235	4,850	2,305	8,649	3,923	8,951	4,060					
	TF470	185.0	4,700	85.6	2,175	39.2	995	60.1	1,527	59	1,496	6	6	4,740	2,260	4,850	2,340	4,680	2,185	4,740	2,265	8,679	3,937	8,981	4,074					
	TF500	196.9	5,000	89.6	2,275	43.1	1,095	64.1	1,627	63	1,596	6	6	4,630	2,210	4,740	2,280	4,570	2,135	4,630	2,205	8,728	3,959	9,030	4,096					
	TF550	216.5	5,500	97.4	2,475	51.0	1,295	71.9	1,827	72	1,827	6	6	3,527	1,600	4,570	2,210	3,850	1,525	4,460	2,135	8,814	3,998	9,116	4,135					
	TF600	236.2	6,000	105.3	2,675	58.9	1,495	79.8	2,027	80	2,027	6	6	2,315	1,050	4,400	2,110	2,640	975	4,290	2,035	8,957	4,063	9,259	4,200					
	TS430	169.3	4,300	79.7	2,025	33.3	845	54.2	1,377	49	1,253	6	6	4,900	2,340	5,000	2,410	4,850	2,265	4,900	2,335	8,601	3,901	8,903	4,038					
	TS450	177.2	4,500	83.7	2,125	37.2	945	58.1	1,477	55	1,403	6	6	4,790	2,310	4,900	2,380	4,740	2,235	4,850	2,305	8,649	3,923	8,951	4,060					
	TS470	185.0	4,700	85.6	2,175	39.2	995	60.1	1,527	55	1,403	6	6	4,740	2,260	4,850	2,340	4,680	2,185	4,740	2,265	8,679	3,937	8,981	4,074					
	TS500	196.9	5,000	89.6	2,275	43.1	1,095	64.1	1,627	59	1,503	6	6	4,630	2,210	4,740	2,280	4,570	2,135	4,630	2,205	8,728	3,959	9,030	4,096					
	TS550	216.5	5,500	97.4	2,475	51.0	1,295	71.9	1,827	70	1,770	6	6	3,527	1,600	4,570	2,210	3,850	1,525	4,460	2,135	8,814	3,998	9,116	4,135					
	TS600	236.2	6,000	105.3	2,675	58.9	1,495	79.8	2,027	77	1,953	6	6	2,315	1,050	4,400	2,110	2,640	975	4,290	2,035	8,957	4,063	9,259	4,200					
4-STAGE FULL FREE LIFT	QF610	240.7	6,115	85.7	2,177	39.3	997	59.5	1,512	58	1,462	3	3	3,400	1,580	3,950	1,810	3,260	1,505	3,730	1,735	9,490	4,305	9,794	4,443					
	QF700	276.2	7,015	97.5	2,477	51.1	1,297	71.3	1,812	69	1,762	3	3	2,690	1,230	3,550	1,630	2,580	1,155	3,370	1,555	9,690	4,396	9,995	4,534					

※ TS-Mast : Wide Visible 3-Stage Full Free Lift Mast with 2 Free Lift Cylinders.

* Standard

Mast Specification (30DF-7)

Mast Type	Maximum Fork Height		Overall Height (Lowered)		Free Lift Height						Tilt Angle		Load capacity w/o side shift				Load capacity w/side shift				TRUCK WEIGHT (UNLOAD)									
					with bkr		w/o bkr		w/o bkr (3/4-SPOOL)		Fwd	Bwd	Single Tire		Double Tire		Single Tire		Double Tire		Single Tire		Double Tire							
	in	mm	in	mm	in	mm	in	mm	in	mm	deg	deg	24 in LC	500mm LC	24 in LC	500mm LC	24 in LC	500mm LC	24 in LC	500mm LC	24 in LC	500mm LC	24 in LC	500mm LC	lb	kg	lb	kg	lb	kg
2-STAGE LIMITED FREE LIFT	*V300	118.1	3,000	80.3	2,040	6.1	155	6.1	155	6.1	155	6	10	6,000	3,000	6,000	3,000	6,000	3,000	6,000	3,000	9,213	4,179	9,404	4,266					
	V330	129.9	3,300	86.2	2,190							6	10	6,000	3,000	6,000	3,000	6,000	3,000	6,000	3,000	9,257	4,199	9,448	4,286					
	V350	137.8	3,500	90.2	2,290							6	10	6,000	3,000	6,000	3,000	6,000	3,000	6,000	3,000	9,297	4,217	9,488	4,304					
	V370	145.7	3,700	96.1	2,440							6	10	6,000	3,000	6,000	3,000	6,000	3,000	6,000	3,000	9,347	4,240	9,538	4,326					
	V400	157.4	4,000	102.0	2,590							6	10	6,000	3,000	6,000	3,000	5,950	2,880	6,000	2,920	9,415	4,271	9,606	4,357					
	V450	177.2	4,500	113.8	2,890							6	6	5,840	2,850	6,000	2,920	5,730	2,750	5,840	2,820	9,581	4,346	9,772	4,433					
3-STAGE FULL FREE LIFT	TF430	169.3	4,300	80.3	2,040	33.9	860	51.7	1,314	46.3	1,175	6	6	5,780	2,830	5,950	2,880	5,670	2,730	5,780	2,780	9,646	4,375	9,835	4,461					
	TF450	177.2	4,500	84.3	2,140	37.8	960	55.7	1,414	52.2	1,325	6	6	5,670	2,780	5,840	2,830	5,560	2,680	5,670	2,730	9,701	4,401	9,891	4,487					
	TF470	185.0	4,700	86.2	2,190	39.8	1,010	57.6	1,464	52.2	1,325	6	6	5,560	2,750	5,730	2,790	5,510	2,650	5,620	2,690	9,733	4,415	9,922	4,501					
	TF500	196.9	5,000	90.2	2,290	43.7	1,110	61.6	1,564	56.1	1,425	6	6	5,450	2,680	5,620	2,730	5,340	2,580	5,510	2,630	9,782	4,437	9,972	4,523					
	TF550	216.5	5,500	98.0	2,490	51.6	1,310	69.4	1,764	65.9	1,675	6	6	5,340	2,580	5,400	2,630	5,180	2,480	5,290	2,530	9,879	4,481	10,069	4,567					
	TF600	236.2	6,000	105.9	2,690	59.4	1,510	77.3	1,964	73.8	1,875	6	6	4,145	1,880	5,230	2,530	4,290	1,780	5,070	2,430	10,034	4,551	10,223	4,637					
	TS430	169.3	4,300	80.3	2,040	33.9	860	51.7	1,314	49.3	1,253	6	6	5,780	2,830	5,950	2,880	5,670	2,730	5,780	2,780	9,646	4,375	9,835	4,461					
	TS450	177.2	4,500	84.3	2,140	37.8	960	55.7	1,414	55.2	1,403	6	6	5,670	2,780	5,840	2,830	5,560	2,680	5,670	2,730	9,701	4,401	9,891	4,487					
	TS470	185.0	4,700	86.2	2,190	39.8	1,010	57.6	1,464	55.2	1,403	6	6	5,560	2,750	5,730	2,790	5,510	2,650	5,620	2,690	9,733	4,415	9,922	4,501					
	TS500	196.9	5,000	90.2	2,290	43.7	1,110	61.6	1,564	59.2	1,503	6	6	5,450	2,680	5,620	2,730	5,340	2,580	5,510	2,630	9,782	4,437	9,972	4,523					
	TS550	216.5	5,500	98.0	2,490	51.6	1,310	69.4	1,764	69.0	1,753	6	6	5,340	2,580	5,400	2,630	5,180	2,480	5,290	2,530	9,879	4,481	10,069	4,567					
	TS600	236.2	6,000	105.9	2,690	59.4	1,510	77.3	1,964	76.9	1,953	6	6	4,145	1,880	5,230	2,530	4,290	1,780	5,070	2,430	10,034	4,551	10,223	4,637					
4-STAGE FULL FREE LIFT	QF610	240.7	6,115	85.6	2,175	37.6	955	57.0	1,449	57.0	1,449	3	3	3,880	1,780	4,960	2,270	3,700	1,680	4,670	2,170	10,429	4,731	10,597	4,807					
	QF700	276.2	7,015	97.4	2,475	51.0	1,295	68.9	1,749	68.9	1,749	3	3	3,020	1,370	4,480	2,050	2,870	1,270	4,230	1,950	10,628	4,821	10,798	4,898					

※ TS-Mast : Wide Visible 3-Stage Full Free Lift Mast with 2 Free Lift Cylinders.

* Standard

Specification

Mast Specification (33DF-7)

Mast Type	Maximum Fork Height		Overall Height (Lowered)		Free Lift Height						Tilt Angle		Load capacity w/o side shift				Load capacity w/side shift				TRUCK WEIGHT (UNLOAD)							
					with bkr		w/o bkr		w/o bkr (3/4-SPOOL)		Fwd	Bwd	Single Tire		Double Tire		Single Tire		Double Tire		Single Tire		Double Tire					
	in	mm	in	mm	in	mm	in	mm	in	mm	deg	deg	24 in LC	500mm LC	24 in LC	500mm LC	24 in LC	500mm LC	24 in LC	500mm LC	lb	kg	lb	kg	lb	kg	lb	kg
2-STAGE LIMITED FREE LIFT	*V300	118.1	3,000	83.1	2,110	6.1	155	6.1	155	6.1	155	6	10	6,500	3,300	6,500	3,300	6,500	3,300	6,500	3,300	9,678	4,390	9,879	4,481			
	V330	129.9	3,300	89.0	2,260							6	10	6,500	3,300	6,500	3,300	6,500	3,300	6,500	3,300	6,500	3,300	9,731	4,414	9,932	4,505	
	V350	137.8	3,500	92.9	2,360							6	10	6,500	3,300	6,500	3,300	6,500	3,300	6,500	3,300	6,500	3,300	9,766	4,430	9,966	4,521	
	V370	145.7	3,700	98.8	2,510							6	10	6,500	3,300	6,500	3,300	6,500	3,300	6,500	3,300	6,500	3,300	9,818	4,454	10,019	4,545	
	V400	157.4	4,000	104.7	2,660							6	10	6,500	3,300	6,500	3,300	6,500	3,300	6,500	3,300	6,500	3,300	9,889	4,486	10,090	4,577	
	V450	177.2	4,500	116.5	2,960							6	6	6,500	3,275	6,500	3,300	6,500	3,200	6,500	3,300	10,059	4,563	10,260	4,654			
3-STAGE FULL FREE LIFT	TF430	169.3	4,300	82.3	2,090	35.8	910	50.0	1,269	50.0	1,269	6	6	6,500	3,200	6,500	3,300	6,390	3,150	6,500	3,225	10,172	4,614	10,372	4,705			
	TF450	177.2	4,500	86.2	2,190	39.8	1,010	53.9	1,369	53.9	1,369	6	6	6,440	3,150	6,500	3,250	6,280	3,075	6,500	3,175	10,220	4,636	10,421	4,727			
	TF470	185.0	4,700	88.2	2,240	41.7	1,060	55.9	1,419	55.9	1,419	6	6	6,330	3,100	6,500	3,200	6,220	3,025	6,390	3,125	10,249	4,649	10,450	4,740			
	TF500	196.9	5,000	92.1	2,340	45.7	1,160	59.8	1,519	59.8	1,519	6	6	6,220	3,050	6,390	3,125	6,110	2,950	6,280	3,050	10,299	4,672	10,500	4,763			
	TF550	216.5	5,500	100	2,540	53.5	1,360	67.7	1,719	67.7	1,719	6	6	5,952	2,700	6,170	3,000	6,000	2,450	6,000	2,925	10,396	4,716	10,596	4,807			
	TF600	236.2	6,000	107.9	2,740	61.4	1,560	75.6	1,919	75.6	1,919	6	6	3,858	1,750	5,950	2,900	3,520	1,450	5,780	2,825	10,555	4,788	10,756	4,879			
	TS430	169.3	4,300	82.3	2,090	35.8	910	50.0	1,269	50.0	1,269	6	6	6,500	3,200	6,500	3,300	6,390	3,150	6,500	3,225	10,172	4,614	10,372	4,705			
	TS450	177.2	4,500	86.2	2,190	39.8	1,010	53.9	1,369	53.9	1,369	6	6	6,440	3,150	6,500	3,250	6,280	3,075	6,500	3,175	10,220	4,636	10,421	4,727			
	TS470	185.0	4,700	88.2	2,240	41.7	1,060	55.9	1,419	55.9	1,419	6	6	6,330	3,100	6,500	3,200	6,220	3,025	6,390	3,125	10,249	4,649	10,450	4,740			
	TS500	196.9	5,000	92.1	2,340	45.7	1,160	59.8	1,519	59.8	1,519	6	6	6,220	3,050	6,390	3,125	6,110	2,950	6,280	3,050	10,299	4,672	10,500	4,763			
4-STAGE FULL FREE LIFT	QF610	240.7	6,115	87.6	2,225	41.1	1,045	57.0	1,449	57.0	1,449	3	3	4,060	1,950	5,840	2,830	3,900	1,850	5,620	2,730	10,844	4,919	11,012	4,995			
	QF700	276.2	7,015	99.4	2,525	53.0	1,345	68.9	1,749	68.9	1,749	3	3	3,240	1,550	5,310	2,580	3,090	1,450	5,110	2,480	11,043	5,009	11,210	5,085			

※ TS-Mast : Wide Visible 3-Stage Full Free Lift Mast with 2 Free Lift Cylinders.

* Standard

Load Capacity

25DF-7

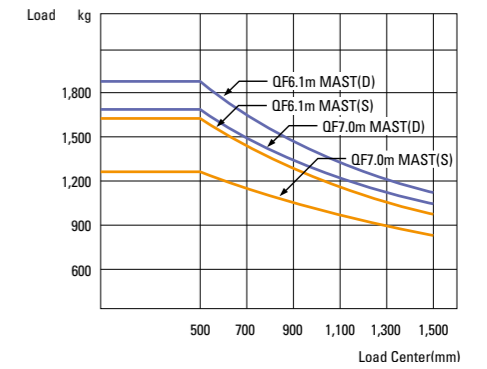
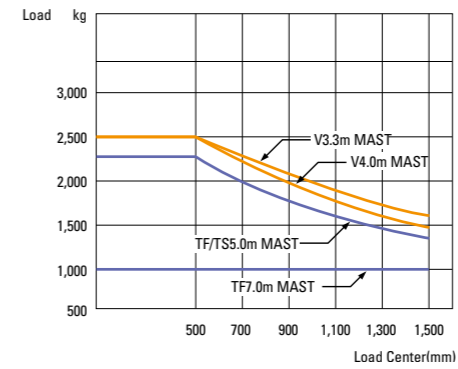

30DF-7

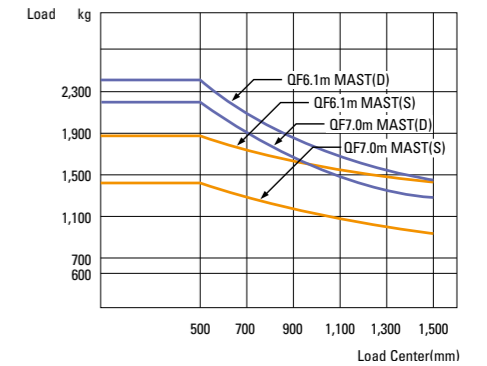
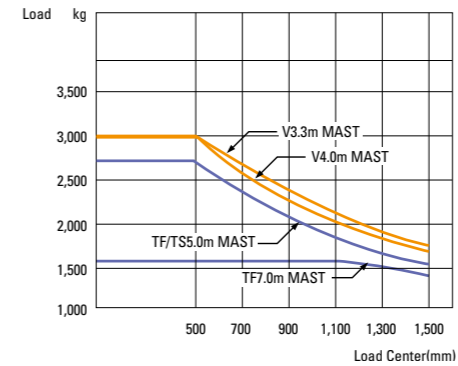

33DF-7

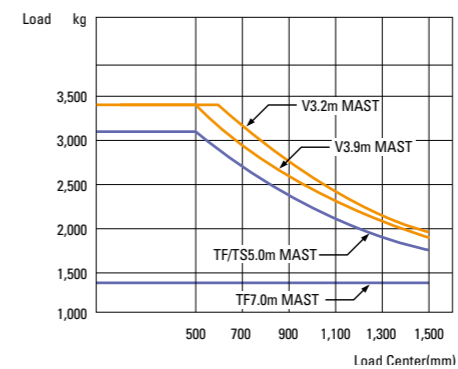

Specification

Various Attachments

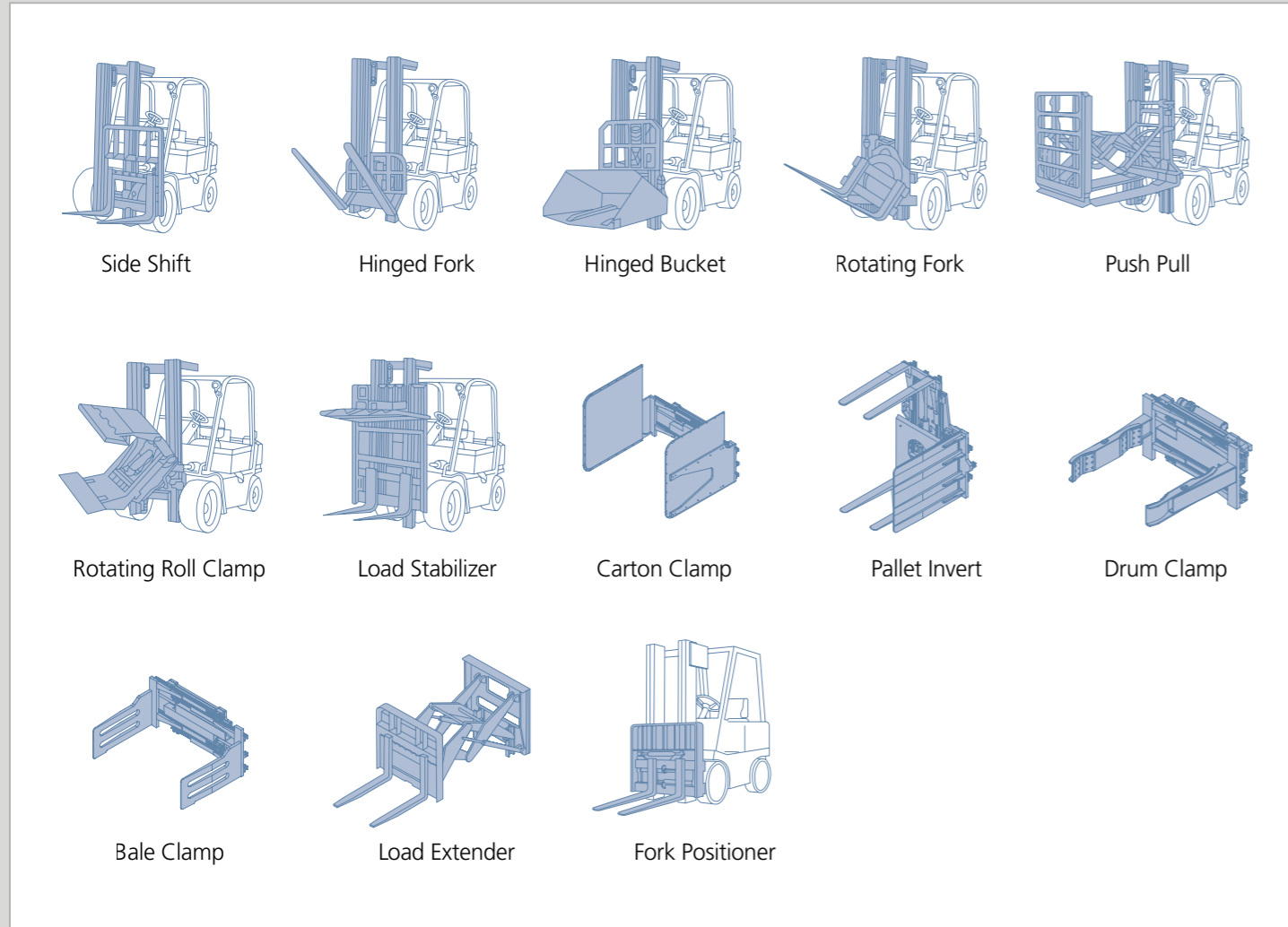

Optional Items

- Fork (LxWxT)(mm)
25DF-7
 900 / 1,000 / 1,050 / 1,200 / 1,350 / 1,500 / 1,650 / 1,800 / 2,100
- 30, 33DF-7**
 900 / 1,050 / 1,150 / 1,200 / 1,350 / 1,500 / 1,650 / 1,800 / 1,970 / 2,120 / 2,300 / 2,400
- Tilting (6°/6°, 3°/3°)
- Sideshift
- Integrated Sideshift
- Attach Piping (3-Spool piping / 4-Spool piping)
- Hose - Reel (VF)
- Seat (Belt, Arm rest)
- Grammer seat (Arm rest, Backrest Ext, Buckle SW)
- Tire (Solid, Double)
- Opss (Travel / Travel + Mast)
- MCV (3-Spool / 4-Spool)

- Beacon Lamp
- Rear Work Lamp
- Pre Cleaner
- TS-MAST
- QF-MAST

Dimension

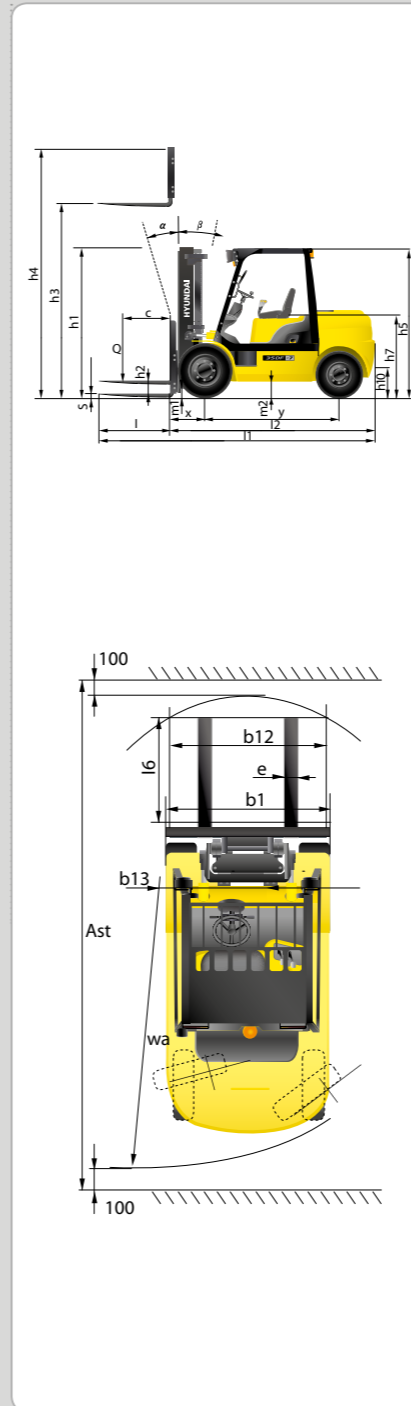

Specification

Identification				
1.1	Manufacturer	Hyundai	Hyundai	Hyundai
1.2	Manufacturer's type designation	25DF-7	30DF-7	33DF-7
1.3	Drive: electric(battery or mains),diesel,petrol,fuel gas,manual	DIESEL	DIESEL	DIESEL
1.4	Type of operation:hand,pedestrian,standing,seated,order-picker	seated	seated	seated
1.5	Load capacity / rated load	kg 2,500	3,000	3,300
1.6	Load center distance	c mm 500	500	500
1.8	Load distance, center of drive axle to fork	x mm 468	468	468
1.9	Wheelbase	y mm 1,650	1,700	1,700
Weights				
2.1	Service weight(including battery)	kg 3,693	4,149	4,443
2.2	Axle loading, loaded front/rear	kg 5,432 / 761	6,281 / 868	6,792 / 951
2.3	Axle loading, unloaded front/rear	kg 1,465 / 2,228	1,572 / 2,577	1,613 / 2,830
Wheels, Chassis				
3.1	Tires:solid rubber, superelastic, pneumatic, polyurethane	pneumatic	pneumatic	pneumatic
3.2	Tires size, front	7.00-12-12PR	8.15-15-14PR	8.15-15-14PR
3.3	Tires size, rear	6.50-10-12PR	6.50-10-12PR	6.50-10-12PR
3.5	Wheels, number front x rear(x=driven wheels)	x2 / 2	x2 / 2	x2 / 2
3.6	Track width, front	mm 965	1,005	1,005
3.7	Track width, rear	mm 980	980	980
Basic Dimensions				
4.1	Mast / fork carriage tilt forward / backward (α/β) degrees	6 / 10	6 / 10	6 / 10
4.2	Lowered mast height	h1 (mm) 2,025	2,040	2,260
4.3	Free lift	h2 (mm) 155	155	155
4.4	Lift height	h3 (mm) 3,005	3,005	3,305
4.5	Extended mast height	h4 (mm) 4,185	4,185	4,485
4.7	Overhead load guard(cab) height	h5 (mm) 2,160	2,180	2,180
4.8	Seat height / standing height	h7 (mm) 1,110	1,130	1,130
4.12	Coupling height	h10 (mm) 283	299	299
4.19	Overall length	l1 (mm) 3,657	3,742	3,782
4.20	Length to face of forks	l2 (mm) 2,607	2,692	2,732
4.21	Overall width	b1 (mm) 1,160	1,230	1,230
4.22	Fork dimensions(hook type)	s / e / l1 (mm) 45x100x1,050	45x122x1,050	45x122x1,050
4.23	Fork carriage ISO 2328, class / type A,B	II / A	III / A	III / A
4.24	Fork-carriage width	b12 (mm) 1,102	1,102	1,102
4.31	Ground clearance, loaded, under mast	m1(mm) 130	145	145
4.32	Ground clearance, centre of wheelbase	m2(mm) 171	189	189
4.33	Aisle width for pallets 1,000x1,200 crossways(LxW)Ast(mm)	3,981	4,066	4,102
4.34	Aisle width for pallets 800x1,200 lengthways(WxL) Ast(mm)	4,181	4,266	4,302
4.35	Turning radius	Wa(mm) 2,313	2,398	2,434
4.36	Smallest pivot point distance	b13(mm) 714	731	731
Performance Data				
5.1	Travel speed, unloaded	km/h 17.6	18.5	18.5
5.2	Lift speed, loaded/ unloaded	mm/s 550 / 590	460 / 480	450 / 480
5.3	Lowering speed, loaded/unloaded	mm/s 500 / 450	500 / 450	500 / 450
5.6	Max. Drawbar pull, loaded	kgf 2,275	2,161	2,162
5.8	Max. Gradeability, loaded/unloaded	% 34.6 / 21.6	27.9 / 20.6	25.9 / 19.2
5.9	Acceleration time, loaded/ unloaded(10m)	sec NA	NA	NA
5.10	Service brake	Hydraulic	Hydraulic	Hydraulic
Engine				
7.1	Engine manufacturer / type	HMC D48B	HMC D48B	HMC D48B
7.2	Engine power acc. to ISO 1585	kW 39	39	39
7.3	Rated speed	1/min 2,500	2,500	2,500
7.4	No. of cylinder / cubic capacity	anz/cm ³ 4 / 2,607	4 / 2,607	4 / 2,607
7.5	Fuel consumption acc. To VDI cycle	ℓ/h 2.4	2.5	2.6
Other Details				
8.1	Type of drive control	power shift	power shift	power shift
8.2	Operating pressure(system / attach)	kgf/cm ² 200 / 165	200 / 165	200 / 165
8.3	Oil volume for attachments	ℓ/min 30 (60 Max.)	30 (60 Max.)	30 (60 Max.)
8.4	Noise	db(A) 80	80	80

■ Contact your Hyundai dealer for more information. The machine shown may vary according to International standards.

