

		DETAILS	25/30/ 35DE/LE-7U			25/30/ 35DE/LE-7U	
OPERATION ROOM	Cabin	Overhead Guard (2,170mm)	●	HYDRAULICS	Steering	Hydraulic Power Steering	●
		Cabin	○		MCV	2 Spool MCV + Attache piping for V300 mast	●
		Top, Front + Top + Rear (With wiper)	○			MCV Option - 3Spool, 4Spool	○
	Seat	Grammer Seat + Belt + Armrest + Buckle switch	○	POWER TRAIN	Transmission	Full Floating Type	●
		Grammer Seat + Belt + Armrest	○		Service Brake	Wet Multi Disc - Service Brake	●
		Non suspension seat + Belt	●			TIRE	Tires
	A/C	Air conditioner	○	Single Solid Tires	○		
	Heater	Heater	○	Single Non-Marking Tires	○		
	Horn-Rear	Rear Horn & Grap Bar	○	VISIBILITY	Lamp-Work	LED Working Lamp - Front & Rear	●
	Extinguishers	Extinguisher (0.7KG)	○		Turn Signal	Turn Signal Lamp	●
Lamp-Beacon					Beacon lamp - Amber	●	
ENGINE	Engine	Mitsubishi S4S (Tier 3)	●	Camera	Camera - Rear, Front & Rear	○	
		HMC L4KB Engine - LPG (Non Certi.)	●	Mirror	Panorama Mirror	○	
		HMC L4KB Engine - Bi-Fuel (Non Certi.)	○		Panorama Mirror + Back Mirror (RH/LH)	●	
		HMC L4KB Engine - LPG (EU Stage V)	○	SAFETY	Master Sw	Master Switch	○
	Lpg Sensor	LPG Empty Alarm	○		Seatbelt Interlock	Seat belt interlock	○
Cleaner	Pre cleaner	○	Opss		OPSS - Travel only	○	
Mast	2 Stage Standard mast (3,000mm)	●		OPSS - Travel & Mast	○		
	Various Option Mast - 2, 3 Stage ¹⁾	○	Load Sensor	Load Sensor	○		
MAST & ATTACHMENT	Fork	1,050mm	●	Speed Control	Travel Speed Control	○	
		Various Option Fork ²⁾	○	OTHERS	LPG Tank Clamp	Fixed	●
	Carriage	Carriage - Hook	●			Swing Out, Swing Down	○
		Carriage - Integral Hook	○	Tank LPG	Include LPG Tank	○	
	Tilt Angle	6F/6B	●				
		6F/10B	○				
Attachment	Side Shift - Hang on, Intergral	○					
	Fork Positioner - Independent, Synchronized	○					

1) Mast Option : V-3,000mm, 3,300mm, 4,000mm, 4,500mm, 5,000mm / VF-2,950mm, 3,250mm, 3,450mm / TF-4,300mm, 4,500mm, 4,700mm, 5,000mm, 5,500mm, 6,000mm ● STD / ○ OPT
 2) Fork Option : 900mm, 1,050mm, 1,150mm, 1,200mm, 1,350mm, 1,500mm, 1,800mm

25/30/ 35DE/LE-7U

Internal Combustion Diesel, LPG Engine Forklift Truck



35DE/LE-7U

Low fuel consumption as well as outstanding comfort and durability!
 Experience the excellent cost-effectiveness unique to the 30DE/LE-7U series.

PRODUCT FEATURES OVERVIEW

■ Optimization of torque ratio
& final reduction

■ Application of slope-type engine mounting
& detachable T/M & D/A

6.7%

Higher fuel efficiency
than 30DE-7

50%

Reduction of vibrations by 50%
compared to 30DE/LE-7

ECONOMICAL
PERFORMANCE

PERFORMANCE UP

- TCO saving - Fuel efficiency increased by 6.7% compared to 30DE-7
- Semi-permanent wet disc brake with excellent credibility
- Application of large-capacity aluminum radiator - Satisfaction of heavy-duty application
- Mitsubishi, HMC engines whose performance, durability, and economy have been proven in the market
- T/M & Drive axle designed considering the environment for heavy-duty work
- Full hydraulic steering system with light operation force and quick, accurate response

SAFETY UP

- LED working lamp to guarantee bright vision during indoor and night work
- Operator Position Sensing System (OPSS) - Limitation of drive, lift, and tilt operations
- Guaranteed wide range of rear view - Basic application of panorama, RH, LH side mirrors
- Fork safety feature - Guaranteed safety when the mast hydraulic line is damaged during work
- Rear grip bar & horn to guarantee driving convenience and safety during backing up **Option**



CONVENIENCE UP

- Slope-type engine mounting + detachable T/M & D/A-Formation of low-vibration driving environment
- Driver's seat designed with ergonomics for consistent comfort at all times
- MCV lever with deck mount structure to minimize movement of driver's arms
- Hood insulation to reduce noise and heat toward the driver's seat
- Grammer full-suspension deluxe seat including cushion-height adjustment function **Option**
- Urethane floor mat to reduce vibrations and noise toward the driver

SERVICE UP

- Application of detachable T/M and D/A - Reduction of follow-up management time and costs compared to the transaxle type
- Side cover and floor plate with tool-less structure to reduce work hours
- Arrangement of mission controller and filters on the upper part of the transmission
- Sub-bonnet made of plastic for the maintenance of radiator only
- Car-style fuse box arranged in front of the dashboard considering the demand for frequent maintenance
- Standard rear cover configuration to prevent inflow of foreign substances under the engine radiator

ENVIRONMENT FRIENDLY
GREAT PRODUCTIVITY, DURABILITY

UP PERFORMANCE

Durability in addition to economically efficient fuel efficiency!

Experience the outstanding cost performance of **30DE/LE-7U**



Engine with credibility and economic efficiency proven in the market

Mitsubishi S4S Diesel & HMC L4KB LPG engines are chosen by a number of forklift truck markets and are products qualified in terms of reliability and cost effectiveness as well as serviceability.

❶ S4S Diesel Engine : Tier 3

❷ L4KB LPG engine :



	Mitsubishi S4S	HMC L4KB
Engine Power (kw/rpm)	35.3/2,250	45.1/2,600
Max Torque (kg·m/rpm)	17.7/1,700	18/2,000
Displacement (cc)	3,331	2,359

Classification	LPG Non-cert	Bi-Fuel Non-Cert	LPG EU emission Stage V
Application	STD	OPT	OPT

25/30/35DE/LE-7U

Transmission with excellent durability and environmental adaptability

A high-capacity clutch pack and a torque converter with excellent torque conversion efficiency are applied to the forward/reverse 1-speed power shift-type transmission for heavy-duty work with frequent push mode and for successful driving on poor roads. The noise level is also reduced with the application of all grinding gear.



Drive axle & wet disc brake

Main components such as shaft and hub manufactured by the forging method are applied to the drive axle in order to show excellent durability in a heavy-duty environment, too. The applied semi-permanent wet disc brake boasts of high credibility and low follow-up maintenance cost compared to the dry disk-type brake.



Enhanced fuel efficiency - Reduced TCO(DE-7U)

The applied new T/M and drive axle for optimum torque ratio and final reduction of the torque converter improved starting acceleration and maximum driving speed. As a result, fuel efficiency is improved by 6.7% compared to the 30DE-7 series, which is the equivalent transaxle-type forklift of the Company (VDI 2198 old version).

Correction of fuel efficiency improvement by

6.7%

Heat radiation performance - Enhanced credibility of power train

An aluminum radiator with excellent durability and heat radiation performance and a cooling fan consisting of 7 blades to reduce engine noise and increase airflow are applied in order to guarantee the perfect radiation performance of the engine and transmission.



LPG/Gasoline : Bi - Fuel System (LE-7U) Option

We have configured the fuel system to allow for the simultaneous use of LPG and gasoline. During operation, if one fuel runs out, you can continue seamlessly by switching to LPG or gasoline without interrupting the process with refueling.



Fully hydraulic power steering

Fully hydraulic power steering without mechanical linkage between steering wheel and steering cylinder and boosting of operability of the wheel by the hydraulic pump reduce the work fatigue of the operator with easy steering operation and agile, secure response.



UP SAFETY

Safety at the logistics site is most important, safety is supported by complete reliability



Operator presence sensing system **Option**

The OPSS restricts driving, lifting, and tilting in when the operator leaves the driver's seat in order to prevent safety accidents.

DRIVE LOCK **LIFT LOCK** **TILT LOCK**



Fork safety features

As the forks are being lowered, a down-control valve maintains a controlled descent speed. The down-safety valve prevents forks from dropping down in case of sudden damage of hydraulic line.

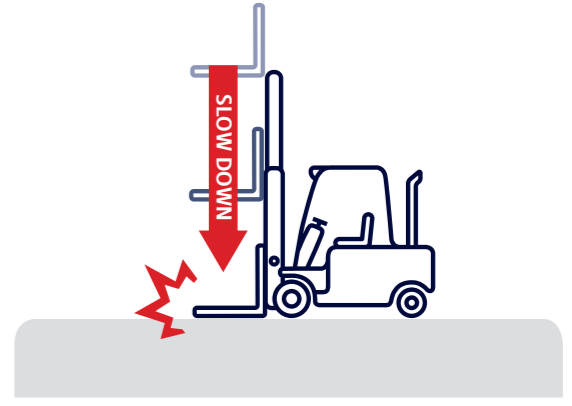

Travel speed control system (LPG) **Option**

Using the travel speed control button, the maximum travel speed of the forklift can be easily selected at the workplace where indoor(Tuttle) and outdoor(Rabbit) works are performed at the same time. When the turtle mode is selected, the travel speed is limited to 8km/h, but mast performance is not limited.



Seat belt interlock **Option**

The seat belt interlock system, which restricts forklift operation when the seat belt-wearing order is not observed or the operator releases the belt while driving, prevents operator injury from safety accidents that may occur when the seat belt is not fastened.



Safety – Lamp & Mirror

LED work lamps, direction indicators, beacon lamps, etc. are basically installed for brighter work vision and to guide the moving direction of the forklift during dark indoor work and night work. Panorama mirror and RH/LH side mirrors are also basically installed to provide driving vision in the rear area.



Parking alarm & Parking interlock

*** Parking alarm**

After turning off the engine, if the parking brake lever is not operated, a warning alarm will go off after a certain period of time.

*** Parking interlock**

During parking brake system operation, the forward and reverse movement of the forklift are restricted for accident prevention.



CONVENIENCE ^{UP}

Increasing work efficiency
to the next level with
consistent convenience in
any condition



Cabin & Air – con, Heater Option

Cabin is composed of three parts: the front windshield, side doors, and rear glass, allowing you to select module or part units according to your usage environment. Additionally, air conditioning and heating are available as separate options.

* Please note the upper rain cover for the head guard is included in the optional specifications.



Load sensing system Option

Cargo weight measurement function configured with pressure sensor of lift line and data convertor provide real time indication of weight of lifted cargo and prompts a load weight monitor.

* The margin of error for weight measuring is $\pm 0.5\%$



Reduced vibrations and comfortable driving

Slope-type engine mounting design for significant engine vibration reduction and power train consisting of separate drive axle and transmission reduce body vibrations by 50% compared to the equipment with integrated transaxle and create a comfortable driving environment.



Grammer Seat Option

The full suspension seat of Grammer of Germany has an adjustable cushion depending on the weight of the driver, and convenience specifications such as seat belt switch, arm rests, and heater are optional.



* Semi-suspension seat is applied by default.

Deck Mount MCV lever

The deck-mounted MCV lever has a feature that reduces movements of the arms of the operator compared to the dashboard-mounted type. In addition, the levers are arranged in the radial direction around the elbow to improve convenience of operation further.



Hood insulation & floor mat

The insulation inside the hood reduces heat and noise from the engine to the cockpit. Furthermore, the polyurethane-foam floor mat reduces vibration and noise from the truck body to provide a pleasant operating environment.



MAINTENANCE ^{UP}

Easy maintenance,
economical service

Satisfaction continues after
completion of the work

LAGER MAINTENANCE SPACE

A large work space is provided for the follow-up management of consumables and major functional parts when you remove the engine compartment cover supported with two gas springs tool-less type side cover and floor plate.



Dual element & Pre-cleaner Option

The air cleaner with 6-inch dual-element structure may be repaired without disassembling surrounding parts by opening the hood. The added optional pre-cleaner also extends the service life of the air cleaner element.



Brake oil reservoir

Oil reservoir is mounted on top of the dashboard for the convenient management of brake oil, which should be frequently inspected and made up for safe operation.



Centralized fuse holders

Fuse is an item demanding the most frequent maintenance works among the components of the electric system of the forklift truck. All of the fuses are centralized on the front of the dashboard for convenient inspection and replacement of fuses.



Transmission maintenance

The transmission separately configured from the drive axle significantly reduces the follow-up maintenance time and cost compared to the integrated transaxle type. In addition, the main functional components, i.e., control valve and filters, are arranged on the upper part of the transmission for easy maintenance.



Detachable radiator cover

The plastic tool-less radiator sub-hood on top of the counterweight separated from the main hood reduces the downtime for checking the cooling water level and makeup.



Specification

IDENTIFICATION							
Manufacturer (Abbreviation)		Hyundai					
Manufacturer's type designation		25DE-7U	30DE-7U	35DE-7U	25LE-7U	30LE-7U	35LE-7U
1.1	Drive : Electric, Diesel, Petrol, Fuel GAS	DIESEL	DIESEL	DIESEL	LPG (Non-Cert) Stage V	LPG (Non-Cert) Stage V	LPG (Non-Cert) Stage V
1.2	Type of operation	seated	seated	seated	seated	seated	seated
1.3	Load capacity	kg	2,500	3,000	3,000	2,500	3,000
1.4	Load center distance	mm	500	500	500	500	500
1.5	Load distance, center of drive axle to fork face	mm	468	468	468	468	468
1.6	Wheelbase	mm	1,650	1,700	1,700	1,650	1,700
WEIGHTS							
2.1	Serveive weight	kg	3,734	4,168	4,529	3,728	4,173
2.2	Axle loading, loaded front/rear	kg	5,481/802	6,384/885	6,384/885	5,434/794	6,286/885
2.3	Axle loading, unloaded fornt/rear	kg	1,514/2,269	1,676/2,593	1,676/2,593	1,467/2,261	1,578/2,594
WHEELS, CHASSIS							
3.1	Tires : Solid rubber, Superelastic, Pneumatic, Polyurethane	Pneumatic	Pneumatic	Pneumatic	Pneumatic	Pneumatic	Pneumatic
3.2	Tire size, frotn	700-12-14PR	28x9-15-16PR	28x9-15-16PR	700-12-14PR	28x9-15-16PR	28x9-15-16PR
3.3	Tire size, rear	6.00-9-10PR	6.50-10-12PR	6.50-10-12PR	6.00-9-10PR	6.50-10-12PR	6.50-10-12PR
3.5	Wheels, number front / rear (X = driven wheels)	2x2	2x2	2x2	2 x 2	2x2	2x2
3.6	Tread, front	mm	965	1,005	1,005	965	1,005
3.7	Tread, rear	mm	980	980	980	980	980
BASIC DIMENSIONS							
4.1	Tilt of mast/fork carriage forward/backward	degree	6/10	6/10	6/10	6/10	6/10
4.2	Height, mast lowered	mm	2,040	2,040	2,040	2,025	2,040
4.3	Free lift	mm	155	155	155	155	155
4.4	Lift height	mm	3,000	3,000	3,000	3,005	3,005
4.5	Height, mast extended	mm	4,180	4,180	4,180	4,185	4,185
4.7	Height of overhead guard (Cabin)	mm	2,160	2,180	2,180	2,160	2,180
4.8	Seat height / Stand height Rel. to SIP	mm	1,185	1,205	1,205	1,185	1,205
4.12	Coupling height	mm	283	299	299	283	299
4.19	Overall length	mm	3,685	3,742	3,827	3,685	3,742
4.20	Length to face of forks	mm	2,635	2,692	2,777	2,635	2,692
4.21	Overall width	mm	1,230	1,230	1,230	1,230	1,230
4.22	Fork dimensions	mm	1,050x100x45	1,050x122x45	1,050x122x45	1,050 x122x45	1,050x122x45
4.23	Fork carriage ISO 2328, Class / Type A, B		II/A	III/A	III/A	II/A	III/A
4.24	Fork-carriage width	mm	1,102	1,102	1,102	1,102	1,102
4.31	Ground clearance, below mast, loaded	mm	145	145	145	145	145
4.32	Ground clearance, center of wheelbase	mm	171	189	189	189	189
4.34.1	Aisle width for pallets 1000 X 1200 crossways	mm	3,981	4,066	4,123	3,981	4,066
4.34.2	Aisle width for pallets 800 X 1200 lengthways	mm	4,181	4,266	4,323	4,181	4,266
4.35	Turning radius	mm	2,313	2,398	2,455	2,313	2,398
4.36	Smallest pivot point distance	mm				714	731
PERFORMANCE DATA							
5.1	Travel speed, loaded / unloaded	km/h	16.2/17.7	17.7/18.8	17.5/18.8	18.0/19.1	18.9/20.1
5.2	Lift speed, loaded / unloaded	mm/s	550/660	450/550	450/550	450/550	450/550
5.3	Lowering speed, loaded / unloaded	mm/s	500/450	500/360	500/360	500/360	500/360
5.6	Max. drawbar pull, loaded / unloaded	kgf	21,212/19,976	18,946/18,603	18,907/18,515	2,012/1,953	1,877/1,837
	Non-Cert Stage V					2,116/2,052	1,975/1,930
5.8	Max. gradeability, loaded / unloaded	%	32.6/22.6	24.8/20.8	22.0/18.4	30.0/21.1	23.9/20.5
	Non-Cert Stage V					31.7/21.1	25.2/20.5
5.10	Service brake		Hydraulic	Hydraulic	Hydraulic	Hydraulic	Hydraulic
ENGINE							
7.1	Engine manufacturer / type		mitsubishi / S4S	mitsubishi / S4S	mitsubishi / S4S	HMC/L4KB	HMC/L4KB
7.2	Engine power acc. To ISO 1585	kW/rpm	35.3/2,250	35.3/2,250	35.3/2,250	45.1/2,600	45.1/2,600
	Non-Cert Stage V					45.4/2,600	45.4/2,600
7.3	Maximum torque	kgf · m/rpm	18/1,700	18/1,700	18/1,700	17.5/2,000	17.5/2,000
	Non-Cert Stage V					18.2/2,000	18.2/2,000
7.4	No. of cylinders / displacement	EA/cc	4/3,331	4/3,331	4/3,331	4/2,359	4/2,359
7.5	Fuel consumption acc. to VDI cycle	l/hr	3.9	4.0	4.2	7.3	7.4
	Non-Cert Stage V					6.4	6.5
OTHER DETAILS							
8.1	Type of drive control		Power Shift	Power Shift	Power Shift	Power Shift	Power Shift
8.2	Operating pressure, system / attachments	bar	210	210	210	210	210
8.3	Oil volume for attachments	LPM	60	60	60	60	60
8.4	Sound level at the driver's ear according to DIN 12053	dB (A)				82.2 83.8	82.2 83.8
8.5	Trailer coupling, type DIN		PIN	PIN	PIN	PIN	PIN

Dimension

25LE-7U	30LE-7U	35LE-7U
Bi-Fuel	Bi-Fuel	Bi-Fuel
seated	seated	seated
2,500	3,000	3,500
500	500	500
468	468	468
1,650	1,700	1,700
3,763	4,206	4,630
5,433/829	6,286/921	7,026/1,104
4,167/2,296	1,577/2,629	1,533/3,097
Pneumatic	Pneumatic	Pneumatic
700-12-14PR	28x9-15-16PR	28x9-15-16PR
6.00-9-10PR	6.50-10-12PR	6.50-10-12PR
2x2	2x2	2x2
965	1005	1005
980	980	980
6/10	6/10	6/10
2,025	2,040	2,040
155	155	155
3,005	3,005	3,005
4,185	4,185	4,185
2,160	2,180	2,180
1,185	1,205	1,205
283	299	299
3,685	3,742	3,827
2,635	2,692	2,777
1,230	1,230	1,230
1,050x122x45	1,050x122x45	1,050x122x45
II/A	III/A	III/A
1,102	1,102	1,102
145	145	145
189	189	189
3,981	4,066	4,123
4,181	4,266	4,323
2,313	2,398	2,455
714	731	731
18.0/19.1	18.9/20.1	18.7/20.1
450/550	450/550	450/550
500/360	500/360	500/360
2,043/1,982	1,905/1,864	1,906/1,856
30.4/21.1	24.3/20.5	21.5/17.8
Hydraulic	Hydraulic	Hydraulic
HMC/L4KB	HMC/L4KB	HMC/L4KB
45.0/2,600	45.0/2,600	45.0/2,600
17.3/2,000	17.3/2,000	17.3/2,000
4/2,359	4/2,359	4/2,359
5	5.1	5.2
Power Shift	Power Shift	Power Shift
210	210	210
60	60	60
82.1	82.1	82.1
PIN	PIN	PIN

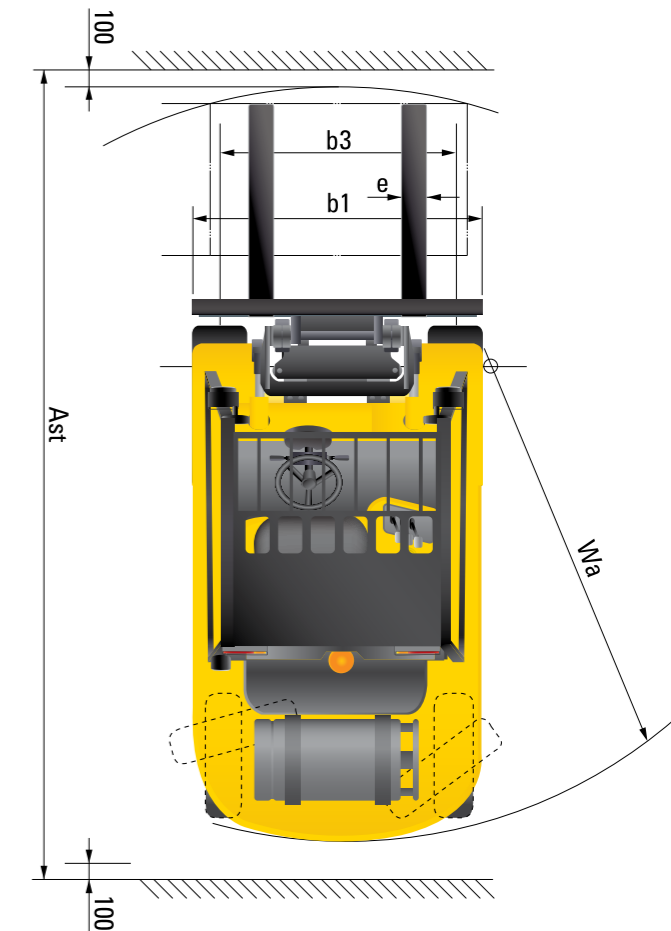
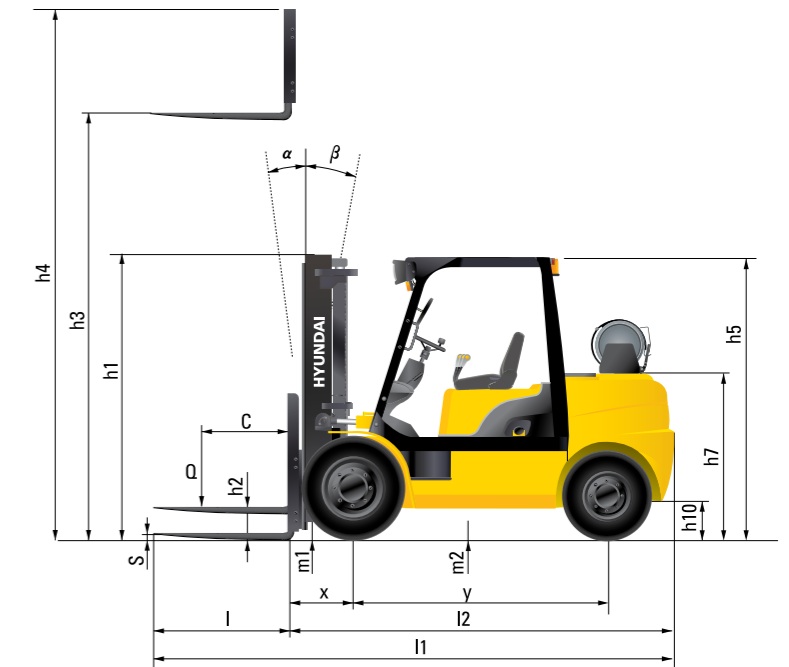

25DE/LE-7U											
Mast Type	Maximum Fork Height	Overall Height (Lowered)	Free Lift Height			Tilt Angle		Load capacity without Side shift	Load Capacity with Integral Side Shift	Truck Weight (Unload)	
			With BKR	Without BKR	Without BKR (3/4-SPOOL)	Fwd	Bwd	500mm LC	500mm LC		
			mm	mm	mm	deg	deg	kg	kg		
2 Stage Limited Free Lift	*V300	3,000	2,040	155	155	155	6	10	2,500	2,500	3,773
	V330	3,300	2,190				6	10	2,500	2,490	3,793
	V400	4,000	2,590				6	10	2,500	2,360	3,862
	V450	4,500	2,890				6	6	2,400	2,270	3,936
	V500	5,000	3,140				6	6	2,310	2,190	3,972
2 Stage Full Free Lift	VF295	2,950	2,025	845	1,361	1,221	6	6	2,500	2,500	3,793
	VF325	3,250	2,175	995	1,511	1,371	6	6	2,500	2,480	3,827
	VF345	3,450	2,275	1,095	1,568	1,428	6	6	2,500	2,440	3,850
3 Stage Full Free Lift	TF430	4,300	2,040	860	1,314	1,175	6	6	2,430	2,290	3,926
	TF450	4,500	2,140	960	1,414	1,275	6	6	2,390	2,250	3,948
	TF470	4,700	2,190	1,010	1,464	1,325	6	6	2,360	2,220	3,961
	TF500	5,000	2,290	1,110	1,564	1,425	6	6	2,310	2,170	3,983
	TF550	5,500	2,490	1,310	1,764	1,675	6	6	2,230	2,090	4,022
	TF600	6,000	2,690	1,510	1,964	1,875	6	6	2,150	2,010	4,087

※ : Standard

35DE/LE-7U											
Mast Type	Maximum Fork Height	Overall Height (Lowered)	Free Lift Height			Tilt Angle		Load capacity without Side shift	Load Capacity with Integral Side Shift	Truck Weight (Unload)	
			With BKR	Without BKR	Without BKR (3/4-SPOOL)	Fwd	Bwd	500mm LC	500mm LC		
			mm	mm	mm	deg	deg	kg	kg		
2 Stage Limited Free Lift	*V300	3,000	2,040	155	155	155	6	10	3,500	3,500	4,560
	V330	3,300	2,190				6	10	3,500	3,450	4,584
	V400	4,000	2,590				6	10	3,500	3,280	4,655
	V450	4,500	2,890				6	6	3,330	3,140	4,732
	V500	5,000	3,140				6	6	3,210	3,030	4,772
2 Stage Full Free Lift	VF295	2,950	2,025	845	1,361	1,221	6	6	3,500	3,500	4,643
	VF325	3,250	2,175	995	1,511	1,371	6	6	3,500	3,410	4,678
	VF345	3,450	2,275	1,095	1,568	1,428	6	6	3,500	3,360	4,714
3 Stage Full Free Lift	TF430	4,300	2,040	860	1,314	1,175	6	6	3,320	3,140	4,829
	TF450	4,500	2,140	960	1,414	1,275	6	6	3,270	3,090	4,850
	TF470	4,700	2,190	1,010	1,464	1,325	6	6	3,220	3,050	4,864
	TF500	5,000	2,290	1,110	1,564	1,425	6	6	3,150	2,990	4,886
	TF550	5,500	2,490	1,310	1,764	1,675	6	6	2,820	2,690	4,930
	TF600	6,000	2,690	1,510	1,964	1,875	6	6	1,810	1,700	5,003

※ : Standard

30DE/LE-7U											
Mast Type	Maximum Fork Height	Overall Height (Lowered)	Free Lift Height			Tilt Angle		Load capacity without Side shift	Load Capacity with Integral Side Shift	Truck Weight (Unload)	
			With BKR	Without BKR	Without BKR (3/4-SPOOL)	Fwd	Bwd	500mm LC	500mm LC		
			mm	mm	mm	deg	deg	kg	kg		
2 Stage Limited Free Lift	*V300	3,000	2,040	155	155	155	6	10	3,000	3,000	4,172
	V330	3,300	2,190				6	10	3,000	2,950	4,192
	V400	4,000	2,590				6	10	2,970	2,790	4,264
	V450	4,500	2,890				6	6	2,850	2,680	4,339
	V500	5,000	3,140				6	6	2,750	2,590	4,377
2 Stage Full Free Lift	VF295	2,950	2,025	845	1,361	1,221	6	6	3,000	3,000	4,218
	VF325	3,250	2,175	995	1,511	1,371	6	6	3,000	2,950	4,251
	VF345	3,450	2,275	1,095	1,568	1,428	6	6	3,000	2,870	4,307
3 Stage Full Free Lift	TF430	4,300	2,040	860	1,314	1,175	6	6	2,850	2,690	4,393
	TF450	4,500	2,140	960	1,414	1,275	6	6	2,800	2,650	4,419
	TF470	4,700	2,190	1,010	1,464	1,325	6	6	2,760	2,610	4,433
	TF500	5,000	2,290	1,110	1,564	1,425	6	6	2,700	2,550	4,455
	TF550	5,500	2,490	1,310	1,764	1,675	6	6	2,600	2,460	4,499
	TF600	6,000	2,690	1,510	1,964	1,875	6	6	1,960	1,850	4,569

※ : Standard

Load Capacity

