

Hyundai 9 Series battery forklift

**15·18**

**20BT-9U**



Some of the photos may include optional equipment.

# Your satisfaction is our priority!

## Compact forklift with proven AC technology

Hyundai introduces the new BT-9U series 3 wheel battery forklift. The BT-9U series features upgrades to the previous series, including new technology that offers higher efficiency, durability and operator convenience.

### Efficiency

- Application of Electric Power Steering System to improve energy efficiency
- Powerful and Sophisticated driving performance due to Dual drive motor
- Light and Precise Fingertip control (OPT)
- Comfortable and efficient Direction & Horn switch (OPT)

### Durability

- Application of ZF Drive System (Drive Axle + Drive motor + Electric Parking Brake) to improve reliability and durability of drive system
- Advanced reliability of information processing due to Dual micom - ZAPI controller
- Semipermanent Oil Cooled Disc Brake
- IP43 Motor & IP65 Controller

### Safety

- Curve Control feature reduces driving speed when turning through a curve
- Anti-Roll Back feature prevents roll back on an incline
- Electric Auto Parking Brake
- Operator Presence Sensing System

### Easy service

- Side Battery Extraction for easy change out
- Self Diagnostics function
- Continental SC18 Solid Tires for longer wear
- Brake oil reservoir with level sensor for easy inspection



Power & Performance

# High Efficiency & Optimal Performance

An efficient, smooth running and compact design provides enhanced performance and outstanding productivity.



Some of the photos may include optional equipment.

## Applied ZF Drive Package (Drive Axle + Drive Motor + Electric Parking Brake) to Dual Drive system UPGRADE

ZF is a top global power train manufacturer, well known for reliability and durability. The ZF dual drive system ensures excellent drawbar pull and short turning radius, and brushless AC motors are virtually maintenance free. An automatic electric parking brake is also applied, which is safe and requires no physical operation.



## Energy consumption Improvement

The energy consumption has been significantly reduced due to newly applied EPS system and ZF drive package. This adoption is expected to decrease the costs and increase the operating time.

Previous Model (20BT-9 : 585Ah) : 251 minutes (100%)

Upgraded Model (20BT-9U : 585Ah) : 304 minutes (121%)

※The figures above are based on Hyundai's test results for a single charge cycle and may differ from actual working conditions.

**UPGRADE**



### EPS (Electric Power Steering) System

EPS system consisting of steering sensor, controller, and steering motor operates only when steering wheel is turned. So unnecessary energy consumption and noise were eliminated. Also, speed-sensitive steering wheel allows the driver to set the steering as desired.

**UPGRADE**



### New ZAPI Controller

The new ZAPI AC controller with dual micom and made by ZAPI monitors the dual signals and detects faults. So it is possible to control the forklift quickly and securely. Also, capacity of drive controller has been increased for driving performance.

**UPGRADE**



### Auto fork leveling system (OPT)

In order to improve productivity the auto fork leveling system by automatically stopping when the forks are level.



### Continental SC18 Solid Tire

Continental SC18 solid tires are equipped as a standard. It ensures low energy consumption and long service life.



### Vehicle Performance optimized for working condition

This function optimizes the performance of vehicle for the purpose of work, such as speed of operation, maximum working time and operator's proficiency.

**H mode** : High performance mode with fast driving speed and fast lifting speed

**N mode** : Normal mode with balanced performance and energy consumption

**E mode** : Economy mode maximizing battery life

Easy & Comfort

# Optimized Ergonomics & Fast and Easy Maintenance

An ideal arrangement of components ensures easy access and convenience for maintenance.



## Spacious operating space

The newly designed operating space was made for more space, a wider field of view and operator comfort.



### Comfortable suspension seat

An attractive and adjustable seat, based on a human engineering design, provides great comfort. Also, the angle of the armrest can be adjusted to reduce the fatigue of the driver.

- Grammer Seat
- Adjustable suspension stiffness based on the driver's weight (45~170kg)
- ELR type seat belt standard
- Heater and Backrest extension (OPT)

Some of the photos may include optional equipment.



### Directional & horn switch on lever (OPT)

Electronic directional control and secondary horn are mounted to the hydraulic lift lever for quick and precise maneuvering.



### Finger tip control levers (OPT)

Ergonomically designed fingertip control levers for improved operator comfort and productivity. The armrest can be adjusted for operator comfort.



### Turtle Mode

When selecting the turtle mode while working in narrow and congested workplace, the travel speed is reduced at a preset speed.

## 4.3 inch LCD color monitor

The LCD color monitor with 4.3 inch graphic smart display allows the operator to identify speed, travel direction, and operating hours and control the machine efficiently. The load indicator displays the load weight in the monitor. The operator can select various performance modes to meet all working conditions. Multilanguage (maximum 11) is available.



### Advanced LCD Monitor

- |  |                              |
|--|------------------------------|
| ① Speed (Digital)                              | ⑦ Turtle/Scroll down         |
| ② Steering wheel position and travel direction | ⑧ ESC/Back                   |
| ③ Battery discharge indicator                  | ⑨ Enter                      |
| ④ Scroll up                                    | ⑩ Low brake oil warning lamp |
| ⑤ Menu/Scroll Left                             | ⑪ Error warning lamp         |
| ⑥ Performance/Scroll right                     | ⑫ High temp warning lamp     |

### UPGRADE



### Easy battery replacement

Guide bar installed on the wall helps the battery to be moved to the right position smoothly when removing and mounting.



### Brake oil reservoir with level sensor

The enhanced brake oil reservoir, located in the upper left dash is equipped with an electronic level sensor and easily visible through the monitor.

Secure & Safety

# Advanced Safety

The safely designed driver's space makes your operating more comfortable.

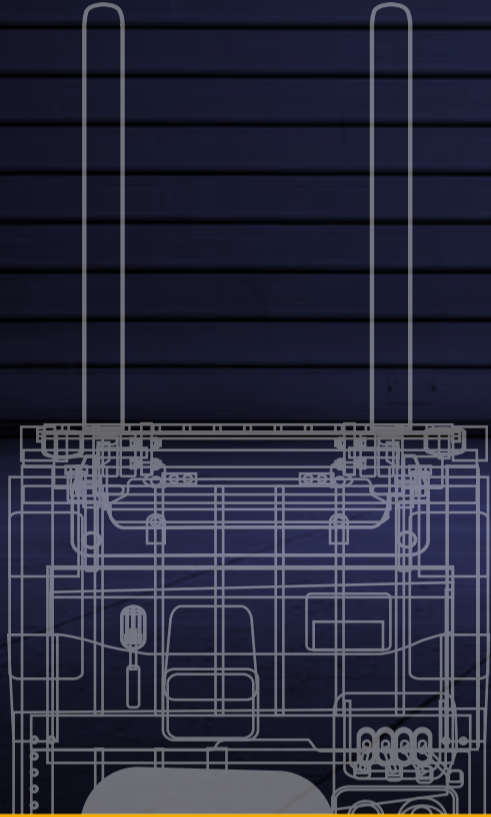

Some of the photos may include optional equipment.



You can see the video by scanning the QR code.

## Excellent visibility for safe operation

Optimized lift cylinder arrangement provides the operator with wider visibility. The panoramic mirror expands the driver's view when backing up.



Some of the photos may include optional equipment.



**Strong overhead guard**

Exceeding ISO6055 regulations, the overhead guard offers great protection combined with excellent all around visibility.



**Safety lamps**

LED combination lights and halogen headlights offer the driver visibility in all circumstances.



**AUTO PARKING**

**Auto parking brake**

No operation is required by the operator after turning off a vehicle. (There are no levers, no switches.)

## Safety features

The adoption of a high-sensitivity sensor and advanced safety system can prevent the safety accidents.



**Anti-roll back system**

This system prevents the forklift from rolling rapidly down a slope when the accel pedal & brake pedal are not applied while also offering improved ramp start-up abilities.

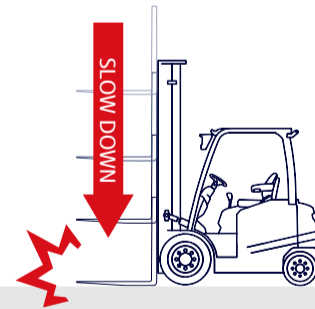

**Fork safety features**

When the forks are being lowered, a down-control valve maintains the controlled speed. The down-safety valve prevents forks from dropping down in case of sudden damage of hydraulic line.



**Operator Presence Sensing System (OPSS)**

When operator is not in seat the hydraulic lift and tilt controls and travel are locked out.

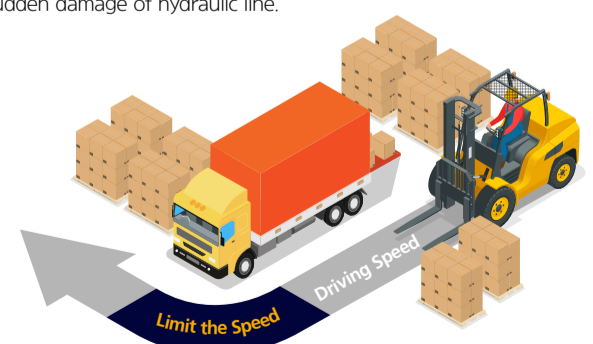

**Curve control**

Curve Control limits travel speed based on turning radius for a smooth, precise turning operation for the driver.



## High quality Li-ION battery (OPT)

Rapidly chargeable Li-ION battery ensure performance of the equipment with vastly reduced charge times, allowing extended hours of continued operation on a single charge. Moreover, it lasts at least twice longer than lead / sulfuric acid counterparts, and does not necessitate management of distilled water. Also, Li-ION battery using the prismatic cells provides excellent performance and safety.



### Benefits of HCE's Li-ION battery



#### Long hours of continuous operation

- Continued operations possible throughout the day with only auxiliary charge during equipment stoppage and meal time.
- No need for spare batteries and charging facilities.



#### Safety

- Multi-layered protection on cell.
- Enclosed battery case made of high-strength steel.
- Prevention of overheating, excessive electricity discharge or recharging through Battery Manage System.



#### Easy maintenance

- No need to replenish distilled water or electrolytes.
- Battery life at least twice longer than that of lead / sulfuric acid batteries. (over 4,000 cycles)
- No emission of harmful gases and no restriction on the charging location.



#### Cost savings

- Charging efficiency higher than lead / sulfuric acid batteries. (80% → 90%)
- 15,000 operational hours guaranteed for 5 years.



- Li-ION battery capacity :
  - 15BT-9U : 51.5V/376Ah
  - 18/20BT-9U : 51.5V/470Ah

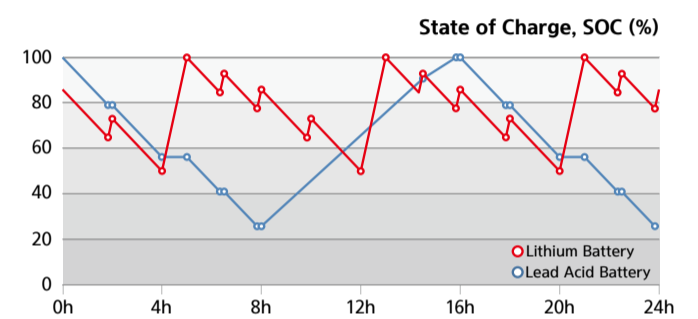

• Graph comparing the charge and discharge

Some of the photos may include optional equipment

## New 9 Series Mast Specification

15/18/20BT-9U

### 15BT-9U

Mast Type	Maximum Fork Height		Overall Height (Lowered)		Free lift height						Tilt Angle		Load capacity w/o side shift		Load capacity w/side shift		Truck Weight (Unloaded)		
					With Load Backrest		Without Load Backrest		Without Load Backrest (3/4-SPOOL)		Fwd	Bwd	24 in LC	500 mm LC	24 in LC	500 mm LC			
	in	mm	in	mm	in	mm	in	mm	in	mm	deg	deg	lb	kg	lb	kg	lb	kg	
2-STAGE LIMITED FREE LIFT	V300	119.3	3,030	77.6	1,972	1.4	35	1.4	35	1.4	35	5	7	3,000	1,500	2,930	1,440	6,885	3,123
	*V330	131.1	3,330	83.5	2,122							5	7	3,000	1,500	2,930	1,440	6,929	3,143
	V350	139.0	3,530	87.5	2,222							5	7	3,000	1,500	2,870	1,440	6,958	3,156
	V370	146.9	3,730	91.4	2,322							5	7	3,000	1,500	2,820	1,440	6,986	3,169
	V400	158.7	4,030	97.3	2,472							5	7	2,950	1,450	2,730	1,400	7,039	3,193
	V450	178.3	4,530	111.1	2,822							5	5	2,840	1,400	2,630	1,340	7,189	3,261
2-STAGE FULL FREE LIFT	VS330/VF330	131.1	3,330	83.5	2,122	44.2	1,122	59.3	1,507	51.6	1,312	5	5	3,000	1,500	2,890	1,440	7,017	3,183
3-STAGE FULL FREE LIFT	TF400	159.1	4,040	73.7	1,872	34.3	872	51.3	1,305	45.8	1,165	5	5	2,910	1,450	2,670	1,390	7,183	3,258
	TF430	170.9	4,340	77.6	1,972	38.3	972	55.3	1,405	49.8	1,265	5	5	2,840	1,400	2,620	1,340	7,227	3,278
	TF450	178.7	4,540	81.6	2,072	42.2	1,072	61.2	1,555	55.7	1,415	5	5	2,800	1,370	2,580	1,320	7,269	3,297
	TF470	186.6	4,740	83.5	2,122	44.2	1,122	61.2	1,555	55.7	1,415	5	5	2,760	1,350	2,540	1,300	7,293	3,308
	TF500	198.4	5,040	87.5	2,222	48.1	1,222	59.6	1,515	59.6	1,515	5	5	2,690	1,300	2,470	1,250	7,337	3,328
	TF550	218.1	5,540	95.4	2,422	56.0	1,422	75.0	1,905	69.5	1,765	5	5	2,580	1,250	2,360	1,200	7,423	3,367
	TF600	237.8	6,040	103.2	2,622	63.9	1,622	82.8	2,105	77.3	1,965	5	5	2,430	1,170	2,230	1,130	7,564	3,431
	TF650	257.5	6,540	111.1	2,822	71.7	1,822	89.9	2,285	84.5	2,145	3	3	1,850	900	1,680	850	7,663	3,476
	TF700	277.2	7,040	119.0	3,022	79.6	2,022	97.0	2,465	91.5	2,325	3	3	1,340	650	1,190	610	7,747	3,514
	TS430	170.9	4,340	77.6	1,972	38.3	972	51.4	1,307	44.8	1,137	5	5	2,840	1,400	2,620	1,340	7,227	3,278
	TS450	178.7	4,540	81.6	2,072	42.2	1,072	57.3	1,457	50.6	1,287	5	5	2,800	1,370	2,580	1,320	7,269	3,297
	TS470	186.6	4,740	83.5	2,122	44.2	1,122	57.3	1,457	50.6	1,287	5	5	2,760	1,350	2,540	1,300	7,293	3,308
	TS500	198.4	5,040	87.5	2,222	48.1	1,222	61.3	1,557	54.6	1,387	5	5	2,690	1,300	2,470	1,250	7,337	3,328
	TS550	218.1	5,540	95.4	2,422	56.0	1,422	71.1	1,807	64.5	1,637	5	5	2,580	1,250	2,360	1,200	7,423	3,367
	TS600	237.8	6,040	103.2	2,622	63.9	1,622	79.0	2,007	72.3	1,837	5	5	2,430	1,170	2,230	1,130	7,564	3,431
TS650	257.5	6,540	111.1	2,822	71.7	1,822	86.0	2,187	79.4	2,017	3	3	1,850	900	1,680	850	7,663	3,476	

※ TS-Mast : Wide Visible 3-Stage Full Free Lift Mast with 2 Free Lift Cylinders.

※ : Standard

### 18BT-9U

Mast Type	Maximum Fork Height		Overall Height (Lowered)		Free lift height						Tilt Angle		Load capacity w/o side shift		Load capacity w/side shift		Truck Weight (Unloaded)		
					With Load Backrest		Without Load Backrest		Without Load Backrest (3/4-SPOOL)		Fwd	Bwd	24 in LC	500 mm LC	24 in LC	500 mm LC			
	in	mm	in	mm	in	mm	in	mm	in	mm	deg	deg	lb	kg	lb	kg	lb	kg	
2-STAGE LIMITED FREE LIFT	V300	119.3	3,030	77.7	1,974	1.4	35	1.4	35	1.4	35	5	7	3,500	1,800	3,500	1,730	7,509	3,406
	*V330	131.1	3,330	83.6	2,124							5	7	3,500	1,800	3,500	1,730	7,555	3,427
	V350	139.0	3,530	87.6	2,224							5	7	3,500	1,800	3,500	1,730	7,584	3,440
	V370	146.9	3,730	91.5	2,324							5	7	3,500	1,800	3,460	1,730	7,610	3,452
	V400	158.7	4,030	97.4	2,474							5	7	3,500	1,750	3,370	1,680	7,665	3,477
	V450	178.3	4,530	111.2	2,824							5	5	3,460	1,700	3,200	1,640	7,813	3,544
2-STAGE FULL FREE LIFT	VS330/VF330	131.1	3,330	83.6	2,124	44.5	1,131	58.2	1,479	58.6	1,489	5	5	3,500	1,800	3,500	1,730	7,641	3,466
3-STAGE FULL FREE LIFT	TF400	159.1	4,040	73.8	1,874	34.7	881	47.4	1,205	45.9	1,165	5	5	3,460	1,700	3,200	1,630	7,809	3,542
	TF430	170.9	4,340	77.7	1,974	38.6	981	47.4	1,205	49.8	1,265	5	5	3,370	1,650	3,110	1,590	7,853	3,562
	TF450	178.7	4,540	81.7	2,074	42.6	1,081	61.2	1,555	55.7	1,415	5	5	3,330	1,620	3,060	1,560	7,895	3,581
	TF470	186.6	4,740	83.6	2,124	44.5	1,131	61.2	1,555	55.7	1,415	5	5	3,260	1,600	3,020	1,530	7,919	3,592
	TF500	198.4	5,040	87.6	2,224	48.5	1,231	65.2	1,655	59.6	1,515	5	5	3,170	1,550	2,930	1,490	7,963	3,612
	TF550	218.1	5,540	95.4	2,424	56.3	1,431	75.0	1,905	69.5	1,765	5	5	2,980	1,450	2,730	1,390	8,049	3,651
	TF600	237.8	6,040	103.3	2,624	64.2	1,631	82.9	2,105	77.4	1,965	5	5	2,380	1,170	2,180	1,130	8,190	3,715
	TF650	257.5	6,540	111.2	2,824	72.1	1,831	90.0	2,285	84.4	2,145	3	3	2,180	1,050	1,980	1,010	8,287	3,759
	TF700	277.2	7,040	119.1	3,024	80.0	2,031	98.4	2,499	92.9	2,359	3	3	1,680	800	1,520	760	8,373	3,798
	TS430	170.9	4,340	77.7	1,974	38.6	981	51.5	1,307	44.8	1,137	5	5	3,370	1,650	3,110	1,590	7,853	3,562
	TS450	178.7	4,540	81.7	2,074	42.6	1,081	57.4	1,457	50.7	1,287	5	5	3,330	1,620	3,060	1,560	7,895	3,581
	TS470	186.6	4,740	83.6	2,124	44.5	1,131	57.4	1,457	50.7	1,287	5	5	3,260	1,600	3,020	1,530	7,919	3,592
	TS500	198.4	5,040	87.6	2,224	48.5	1,231	61.3	1,557	54.6	1,387	5	5	3,170	1,550	2,930	1,490	7,963	3,612
	TS550	218.1	5,540	95.4	2,424	56.3	1,431	71.1	1,807	64.4	1,637	5	5	2,980	1,450	2,730	1,390	8,049	3,651
	TS600	237.8	6,040	103.3	2,624	64.2	1,631	79.0	2,007	72.3	1,837	5	5	2,380	1,170	2,180	1,130	8,190	3,715
TS650	257.5	6,540	111.2	2,824	72.1	1,831	86.1	2,187	79.4	2,017	3	3	2,180	1,050	1,980	1,010	8,287	3,759	

※ TS-Mast : Wide Visible 3-Stage Full Free Lift Mast with 2 Free Lift Cylinders.

※ : Standard

# New 9 Series

15/18/20BT-9U

## 20BT-9U

Mast Type	Maximum Fork Height		Overall Height (Lowered)		Free lift height						Tilt Angle		Load capacity w/o side shift		Load capacity w/side shift		Truck Weight (Unloaded)		
	in	mm	in	mm	With Load Backrest		Without Load Backrest		Without Load Backrest (3/4-SPOOL)		Fwd deg	Bwd deg	24 in LC lb	500 mm LC kg	24 in LC lb	500 mm LC kg	lb	kg	
					in	mm	in	mm	in	mm									
2-STAGE LIMITED FREE LIFT	V300	119.3	3,030	77.7	1,974	1.6	40	1.6	40	1.6	40	5	7	4,000	2,000	3,900	1,920	7,804	3,540
	*V330	131.1	3,330	83.6	2,124							5	7	4,000	2,000	3,880	1,920	7,851	3,561
	V350	139.0	3,530	87.6	2,224							5	7	4,000	2,000	3,810	1,920	7,879	3,574
	V370	146.9	3,730	91.5	2,324							5	7	4,000	2,000	3,770	1,920	7,906	3,586
	V400	158.7	4,030	97.4	2,474							5	7	3,970	1,950	3,680	1,880	7,961	3,611
	V450	178.3	4,530	111.2	2,824							5	5	3,770	1,850	3,480	1,780	8,108	3,678
2-STAGE FULL FREE LIFT	VS330/VF330	131.1	3,330	83.6	2,124	44.7	1,136	59.7	1,516	58.8	1,494	5	5	4,000	2,000	3,860	1,920	7,937	3,600
3-STAGE FULL FREE LIFT	TF400	159.1	4,040	73.8	1,874	34.9	886	51.6	1,310	46.1	1,170	5	5	3,900	1,900	3,620	1,830	8,104	3,676
	TF430	170.9	4,340	77.7	1,974	38.8	986	55.5	1,410	50.0	1,270	5	5	3,810	1,850	3,530	1,790	8,148	3,696
	TF450	178.7	4,540	81.7	2,074	42.8	1,086	61.4	1,560	55.9	1,420	5	5	3,750	1,820	3,460	1,770	8,190	3,715
	TF470	186.6	4,740	83.6	2,124	44.7	1,136	61.4	1,560	55.9	1,420	5	5	3,680	1,800	3,420	1,740	8,214	3,726
	TF500	198.4	5,040	87.6	2,224	48.7	1,236	65.4	1,660	59.8	1,520	5	5	3,620	1,750	3,350	1,690	8,258	3,746
	TF550	218.1	5,540	95.4	2,424	56.5	1,436	75.2	1,910	69.7	1,770	5	5	3,480	1,700	3,220	1,640	8,344	3,785
	TF600	237.8	6,040	103.3	2,624	64.4	1,636	83.1	2,110	77.6	1,970	5	5	3,200	1,550	2,950	1,500	8,485	3,849
	TF650	257.5	6,540	111.2	2,824	72.3	1,836	90.2	2,290	84.6	2,150	3	3	2,600	1,200	2,380	1,150	8,582	3,893
	TF700	277.2	7,040	119.1	3,024	80.2	2,036	98.6	2,504	93.1	2,364	3	3	2,180	1,050	1,980	1,010	8,668	3,932
	TS430	170.9	4,340	77.7	1,974	38.8	986	51.7	1,312	45.0	1,142	5	5	3,810	1,850	3,530	1,790	8,148	3,696
	TS450	178.7	4,540	81.7	2,074	42.8	1,086	57.6	1,462	50.9	1,292	5	5	3,750	1,820	3,460	1,770	8,190	3,715
	TS470	186.6	4,740	83.6	2,124	44.7	1,136	57.6	1,462	50.9	1,292	5	5	3,680	1,800	3,420	1,740	8,214	3,726
	TS500	198.4	5,040	87.6	2,224	48.7	1,236	61.5	1,562	54.8	1,392	5	5	3,620	1,750	3,350	1,690	8,258	3,746
	TS550	218.1	5,540	95.4	2,424	56.5	1,436	71.3	1,812	64.6	1,642	5	5	3,480	1,700	3,220	1,640	8,344	3,785
	TS600	237.8	6,040	103.3	2,624	64.4	1,636	79.2	2,012	72.5	1,842	5	5	3,200	1,550	2,950	1,500	8,485	3,849
	TS650	257.5	6,540	111.2	2,824	72.3	1,836	86.3	2,192	79.6	2,022	3	3	2,600	1,200	2,380	1,150	8,582	3,893

※ TS-Mast : Wide Visible 3-Stage Full Free Lift Mast with 2 Free Lift Cylinders.

※ : Standard

## New 9 Series

### Load Capacity

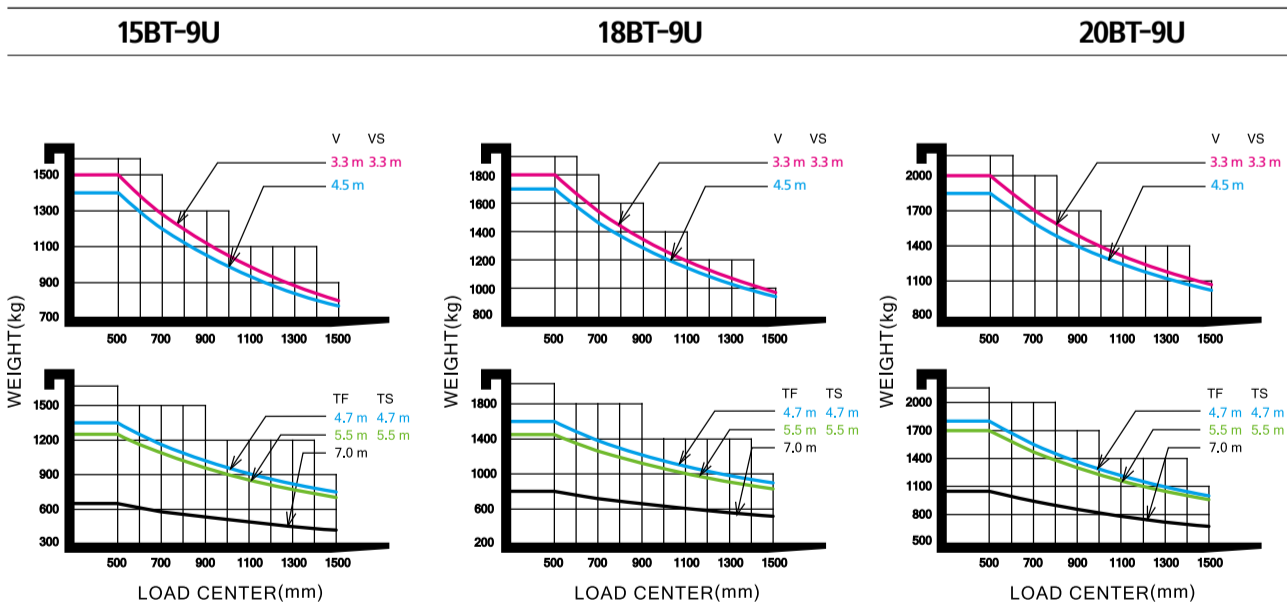

### Various Attachments

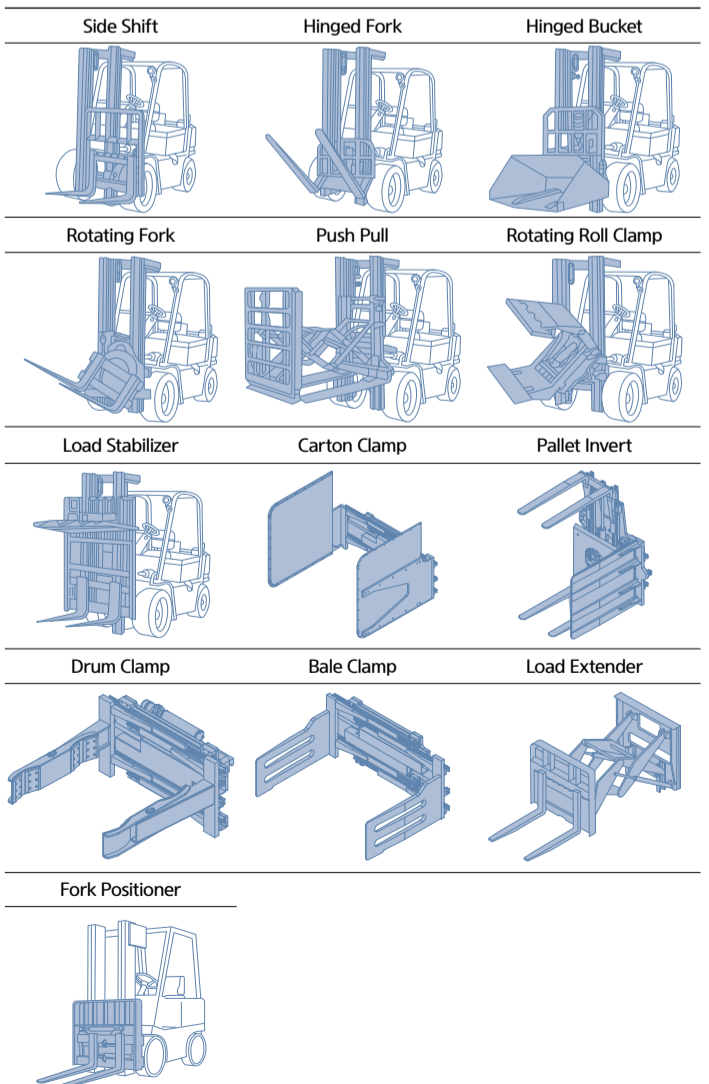

### Optional Items

- Fork (mm) : 40x100x900(STD) / 950 / 1,000 / 1,050 / 1,150 / 1,200 / 1,350 / 1,500 / 1,600
- Integral Sideshift      · Finger Tip Control      · Direction Switch on Lever
- Tire : Non-marking / Wide tire [15BT-9U : Front tire (200 / 50-10)]      · Cold Storage (for - 30°C cold working environments)
- M.C.V : 2-Spool (STD), 3-Spool, 4-Spool      · Auto Fork Leveling      · Beacon Lamp      · Load Indicator
- Work lamp : LED      · OPSS : Mast      · UL : ES, EE      · Cabin

## Specification

DISTINGUISHING MARK				
1.1	Manufacturer (Abbreviation)	Hyundai		
1.2	Manufacturer's Type Designation	15BT-9U	18BT-9U	20BT-9U
1.3	Drive : Electric (Battery Or Mains), Diesel, Petrol, Fuel Gas	electric	electric	electric
1.4	Type Of Operation: Hand, Pedestrian, Standing, Seated, Order-Picker	seated	seated	seated
1.5	Load Capacity / Rated Load	Kg (Lb) 1,500 (3,000)	1,800 (3,500)	2,000 (4,000)
1.6	Load Center Distance	c mm (in) 500 (24)	500 (24)	500 (24)
1.8	Load Distance, Center Of Drive Axle To Fork	x mm (in) 380 (14.96)	380 (14.96)	380 (14.96)
1.9	Wheelbase	y mm (in) 1,345 (53.0)	1,430 (56.30)	1,430 (56.30)
WEIGHT				
2.1	Service Weight	kg (lb) 3,118 (6,874)	3,407 (7,511)	3,542 (7,809)
2.2	Axle Loading, Loaded Front / Rear	kg (lb) 4,129/489 (8,842/1,032)	4,642/565 (9,748/1,263)	4,956/586 (10,572/1,237)
2.3	Axle Loading, Unloaded Front / Rear	kg (lb) 1,654/1,464 (3,646/3,228)	1,741/1,666 (3,838/3,673)	1,725/1,817 (3,804/4,005)
TIRES, CHASSIS				
3.1	Tires : Solid Rubber, Superelastic, Pneumatic, Polyurethane	SE	SE	SE
3.2	Tire Size, Front	18x7-8	200/50-10	200/50-10
3.3	Tire Size, Rear	15x4.5-8	15x4.5-8	15x4.5-8
3.5	Wheels, Number Front / Rear (X = Driven Wheels)	2x/2	2x/2	2x/2
3.6	Tread, Front	mm (in) 895 (35.2)	905 (35.6)	905 (35.6)
3.7	Tread, Rear	mm (in) 184 (7.24)	184 (7.24)	184 (7.24)
DIMENSIONS				
4.1	Tilt Of Mast/Fork Carriage Forward/Backward	degree 5/7	5/7	5/7
4.2	Height, Mast Lowered	h1 mm (in) 2,120 (83.5)	2,120 (83.5)	2,120 (83.5)
4.3	Free Lift	h2 mm (in) 35 (1.4)	35 (1.4)	40 (1.5)
4.4	Lift Height	h3 mm (in) 3,330 (131.10)	3,330 (131.10)	3,330 (131.10)
4.5	Height, Mast Extended	h4 mm (in) 4,320 (170.07)	4,320 (170.07)	4,320 (170.07)
4.7	Height Of Overhead Guard (Cabin)	h5 mm (in) 2,065 (81.29)	2,065 (81.29)	2,065 (81.29)
4.8	Seat Height / Stand Height Rel. To Sip	h7 mm (in) 1,090 (42.91)	1,090 (42.91)	1,090 (42.91)
4.12	Coupling Height	h10 mm (in) 520 (20.5)	520 (20.5)	520 (20.5)
4.19	Overall Length	l1 mm (in) 2,800 (110.24)	2,890 (113.8)	2,925 (114.56)
4.20	Length To Face Of Forks	l2 mm (in) 1,900 (78.35)	1,990 (78.3)	2,025 (79.72)
4.21	Overall Width	b1 mm (in) 1,074 (42.28)	1,105 (43.50)	1,105 (43.50)
4.22	Fork Dimensions	s x e x l mm (in) 40x100x900 (1.6x4x35.4)	40x100x900 (1.6x4x35.4)	40x100x900 (1.6x4x35.4)
4.23	Fork Carriage Iso 2328, Class / Type A, B	2A	2A	2A
4.24	Fork-Carriage Width	b3 mm (in) 1,006 (39.60)	1,006 (39.60)	1,006 (39.60)
4.31	Ground Clearance, Below Mast, Loaded	m1 mm (in) 89 (3.50)	89 (3.50)	89 (3.50)
4.32	Ground Clearance, Center Of Wheelbase	m2 mm (in) 95 (3.74)	95 (3.74)	95 (3.74)
4.33	Aisle Width For Pallets 1,000 X 1,200 Crossways (L X W)	Ast mm (in) 3,245 (127.75)	3,335 (131.29)	3,365 (132.48)
4.34	Aisle Width Of Pallets 800 X 1,200 Crossways (W X L)	Ast mm (in) 3,370 (132.67)	3,460 (136.22)	3,490 (137.40)
4.35	Turning Radius	Wa mm (in) 1,540 (60.62)	1,630 (64.17)	1,660 (65.35)

PERFORMANCE DATA					
5.1	Travel Speed, Loaded / Unloaded	km/h (mph)	16/16 (9.9/9.9)	16/16 (9.9/9.9)	16/16 (9.9/9.9)
5.2	Lift Speed, Loaded / Unloaded	mm/s (ft/min)	400/550 (78.7/108.3)	400/550 (78.7/108.3)	400/550 (78.7/108.3)
5.3	Lowering Speed, Loaded / Unloaded	mm/s (ft/min)	550/450 (108.3/88.6)	550/450 (108.3/88.6)	550/450 (108.3/88.6)
5.6	Max. Drawbar Pull, Loaded / Unloaded	N (lb)	15,102/14,759 (3,395/3,318)	15,190/14,710 (3,415/3,306)	14,367/14,043 (3,229.7/3,156)
5.8	Max. Gradeability, Loaded / Unloaded	%	29.5/-	27.5/-	24.5/-
5.10	Service Brake		hydr.	hydr.	hydr.
ELECTRIC-MOTOR					
6.1	Drive Motor Rating S2 60 Min	kW (hp)	5.4x2 (7.3x2)	5.4x2 (7.3x2)	5.4x2 (7.3x2)
6.2	Lift Motor Rating At S3 15%	kW (hp)	14.9 (20.3)	14.9 (20.3)	14.9 (20.3)
6.4	Battery Voltage, Nominal Capacity K5	V/Ah	48/440	48/510	48/510
6.5	Battery Weight (Min.)	Kg (lb)	820 (1,808)	1,000 (2,205)	1,000 (2,205)
6.7	Battery Compartment Dimensions L/W/H	mm (in)	983/553/650 (38.7/21.8/25.6)	983/638/650 (38.7/25.1/27.6)	983/638/650 (38.7/25.1/27.6)
ADDITION DATA					
8.1	Type Of Drive Control	AC	AC	AC	AC
8.2	Operating Pressure, System / Attachments	bar (psi)	190/130 (2,755/1,885)	190/130 (2,755/1,885)	190/130 (2,755/1,885)
8.3	Oil Volume For Attachments	LPM	26	26	26

## Dimension

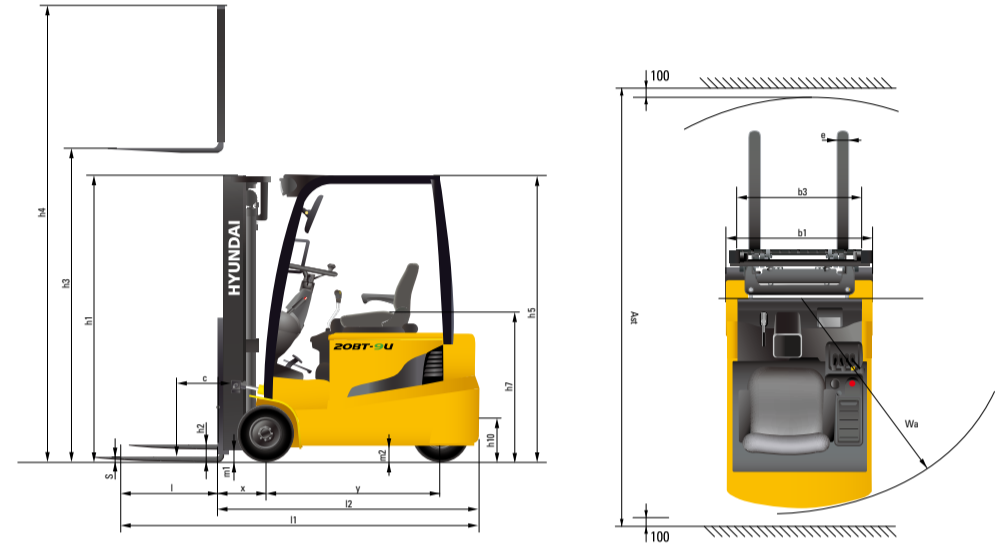

\* All specifications in this catalog are subject to change according to the optional items.

# MEMO

